



Building Materials

Lecture 4



Mechanical properties

- continuation



Modulus of elasticity

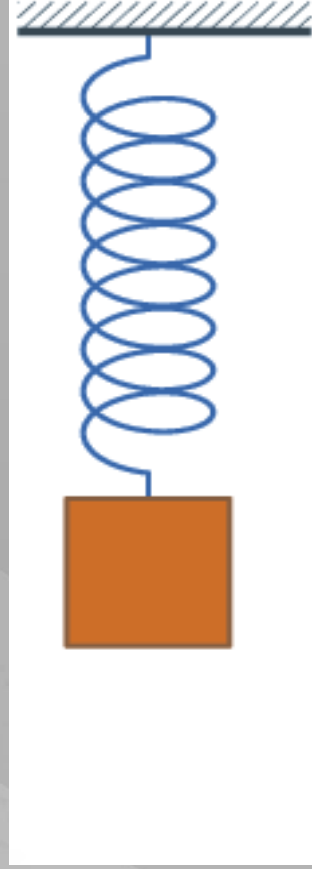



Elastic behavior of materials describes

Hooke's Law :

$$\sigma = E \cdot \varepsilon$$

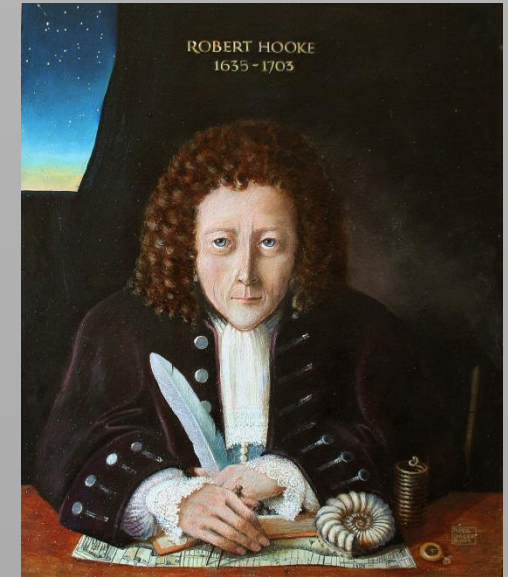

Robert Hooke
1635-1703

ε ... strain [unitless]

σ ... stress [MPa]

E ... modulus of elasticity [MPa]
(Young's modulus)



Elastic modulus

$$E = \frac{\sigma}{\varepsilon_{el}}$$

- the mathematical description of a material's tendency to be deformed elastically when a force is applied to it
- Hooke's law is valid only for **elastic range of material**



Elastic modulus

tension or compression – Young's modulus

$$E = \frac{\sigma}{\epsilon_{el}}$$



Thomas Young (1773-1829)

shear – modulus of rigidity or shear modulus

$$G = \frac{\tau}{\gamma}$$



Deformation

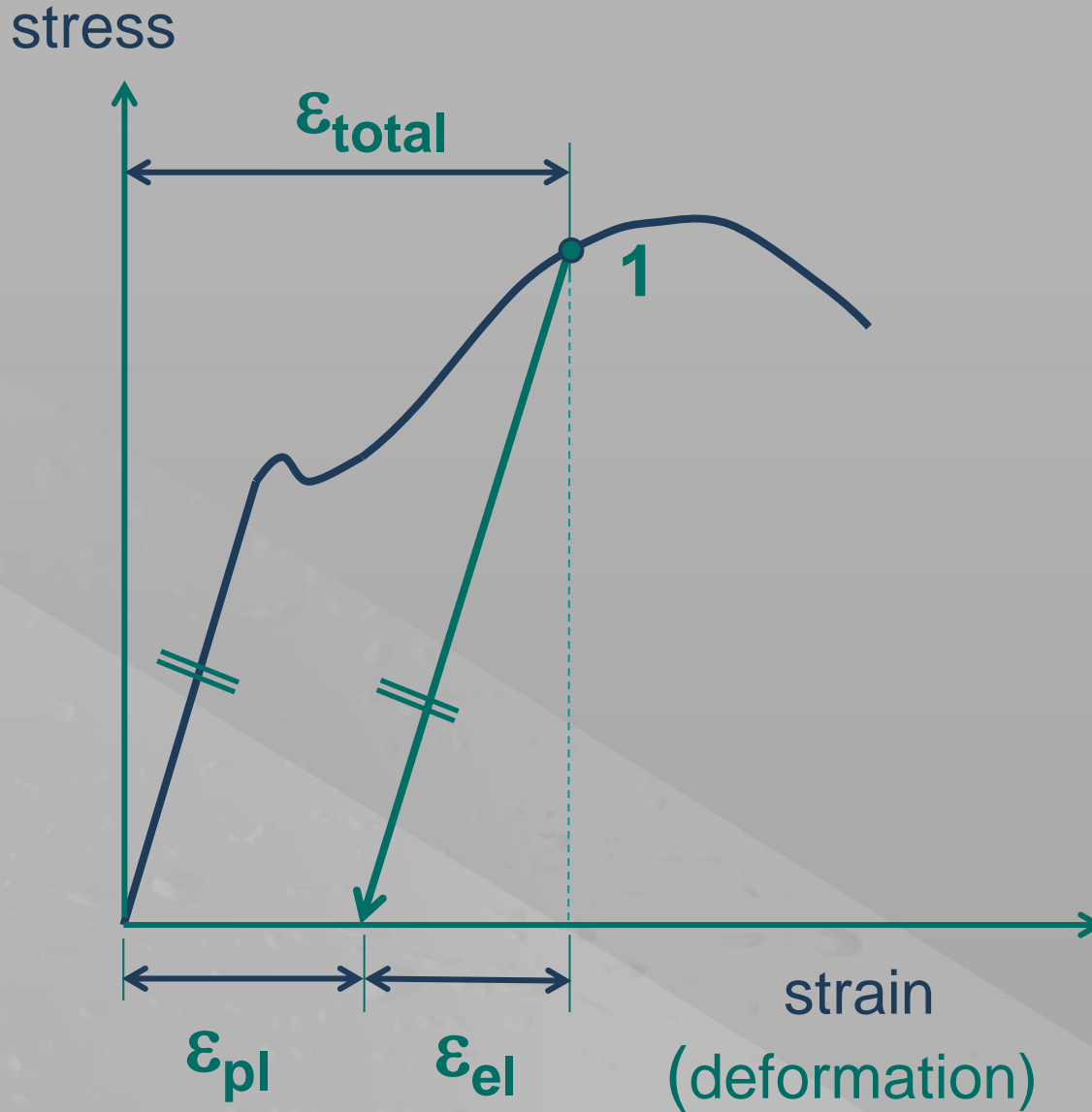

ϵ_{total} - total deformation

ϵ_{el} - elastic deformation

ϵ_{pl} - plastic deformation



Graphical determination of Young's Modulus

$$E = \frac{\sigma}{\epsilon_{el}}$$

$$E = \operatorname{tg} \alpha$$

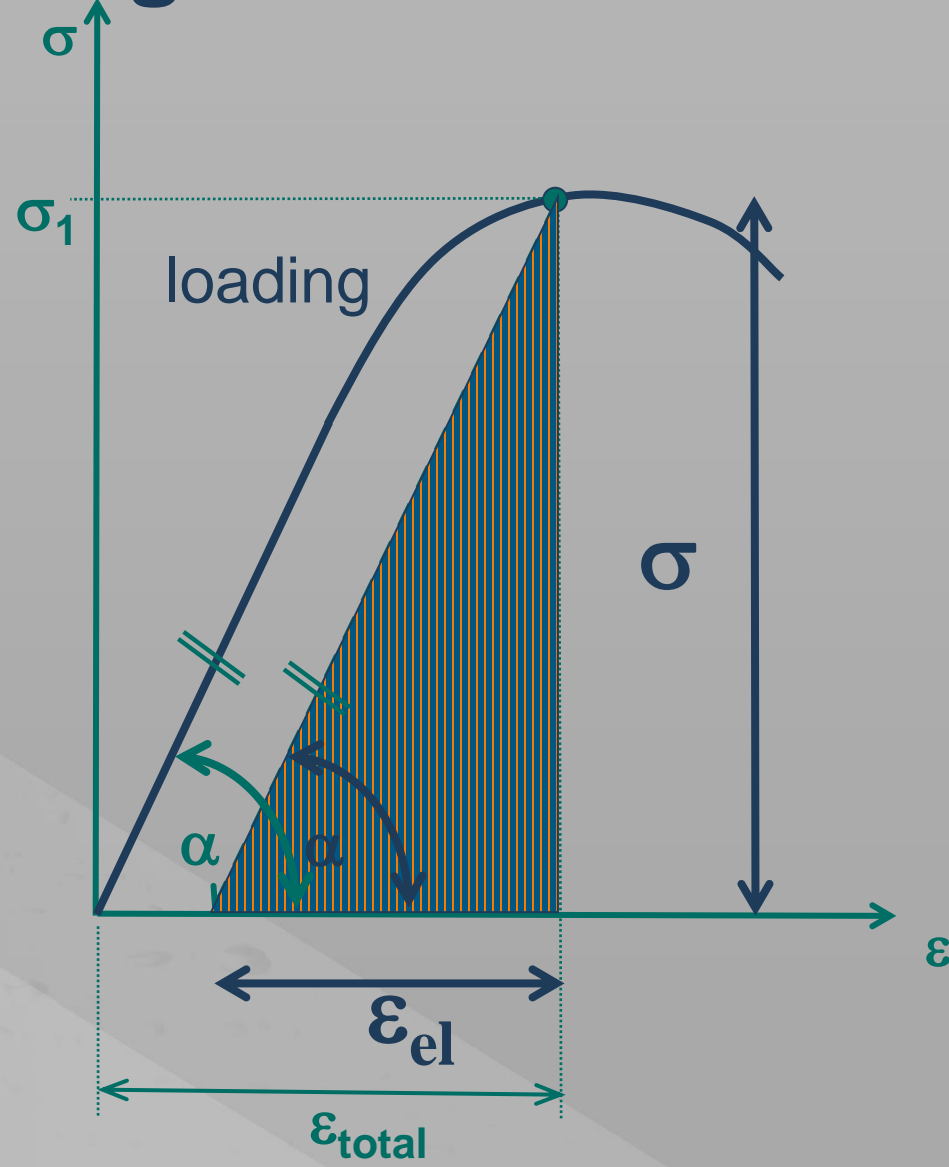

statical

$$E = \frac{\sigma}{\varepsilon_{el}}$$

σ stress [MPa]

ε strain [-]

Young's modulus determination



Young's modulus determination

Stress σ :

- according the type of loading

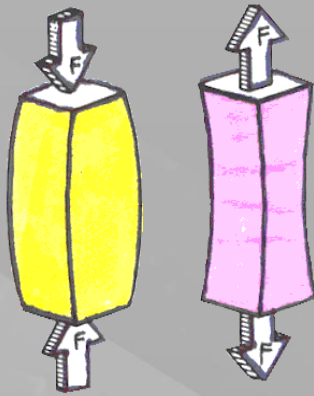

compression
tension

$$\sigma = \frac{F}{A}$$

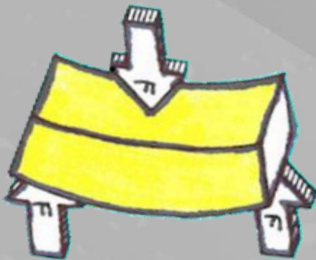

bending

$$\sigma = \frac{M}{W}$$



Young's modulus determination

- strain ϵ

$$\epsilon = \frac{\Delta l}{l_0} = \frac{l_1 - l_0}{l_0}$$

Δl change of the length [mm]

l_1 length after elongation [mm]

l_0 original (initial) length [mm]

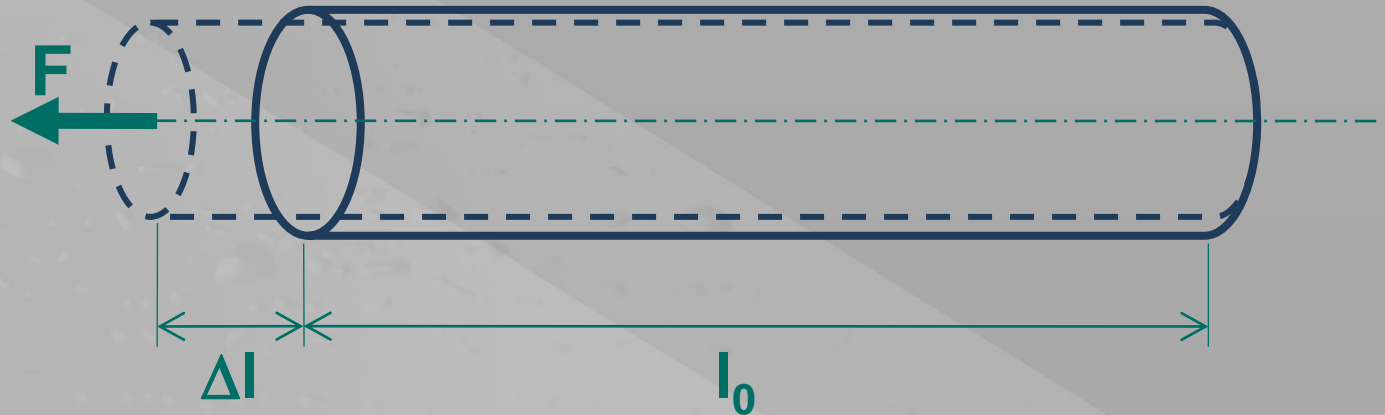
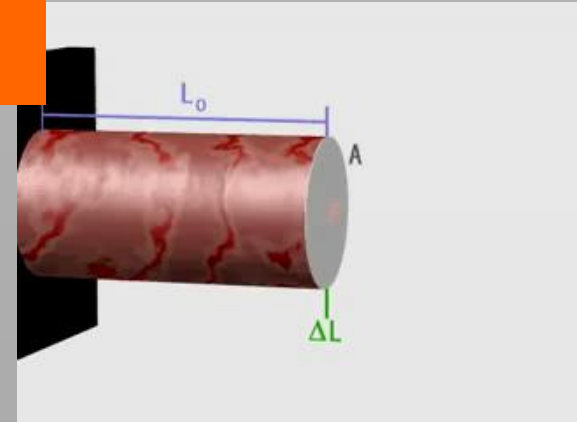



Measuring of elongation Δl

- deformations Δl have to be measured by special devices - **strain gauge**

Strain gauge:

- mechanical
- electrical
- optical

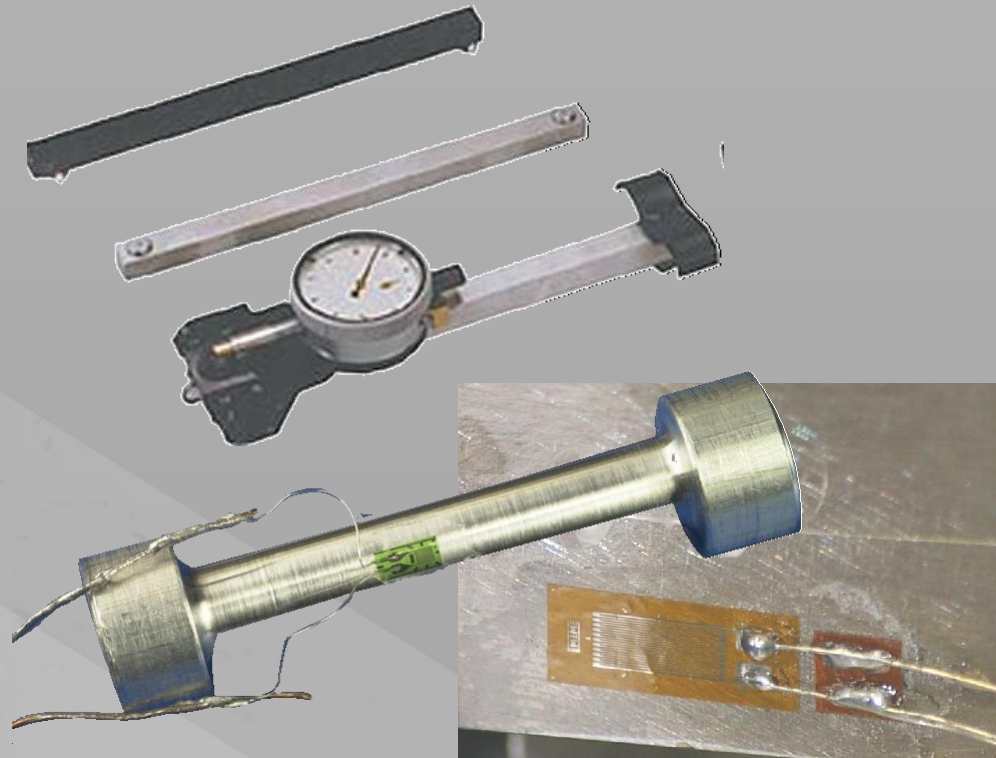



Mechanical strain gauge

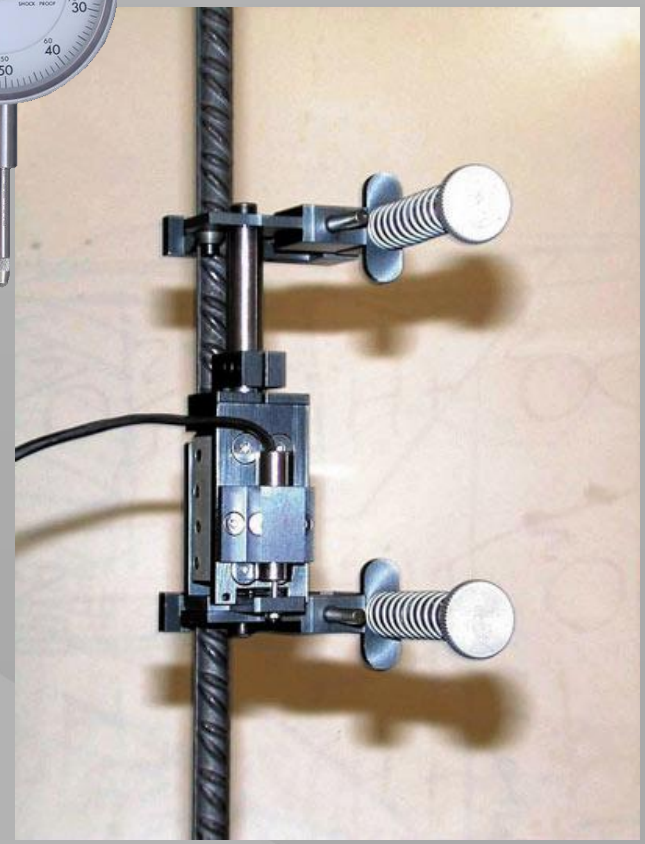
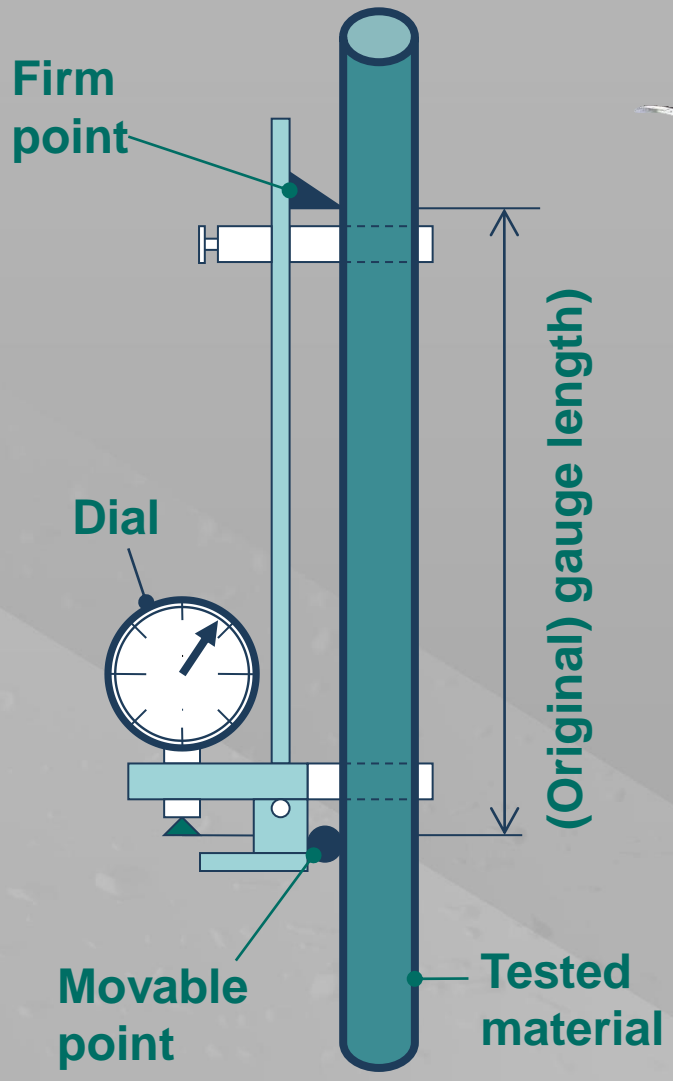



Measuring of deformations



08/07/2009 12:53





Electrical resistance gauge

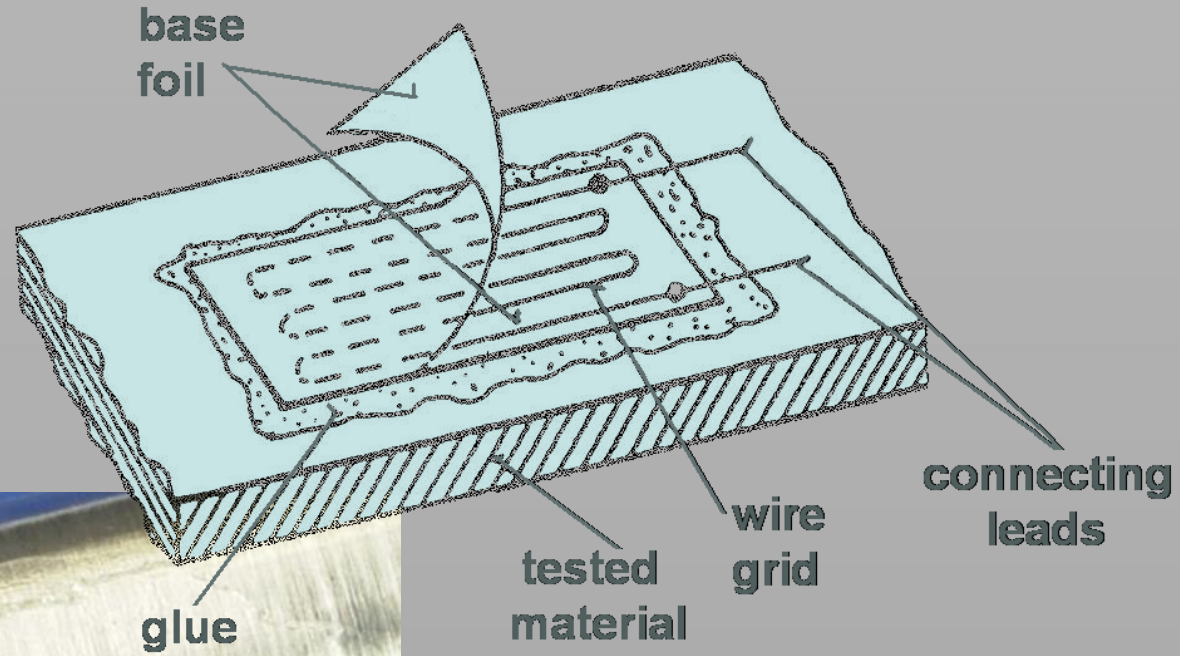

$$\frac{\Delta I}{I} = \frac{1}{K} \cdot \frac{\Delta R}{R}$$



Optical strain gauge

- optical fibers
- laser

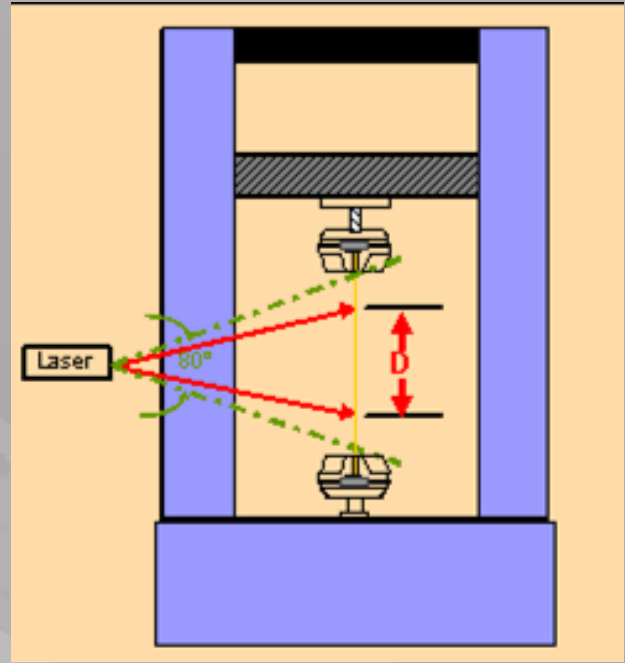
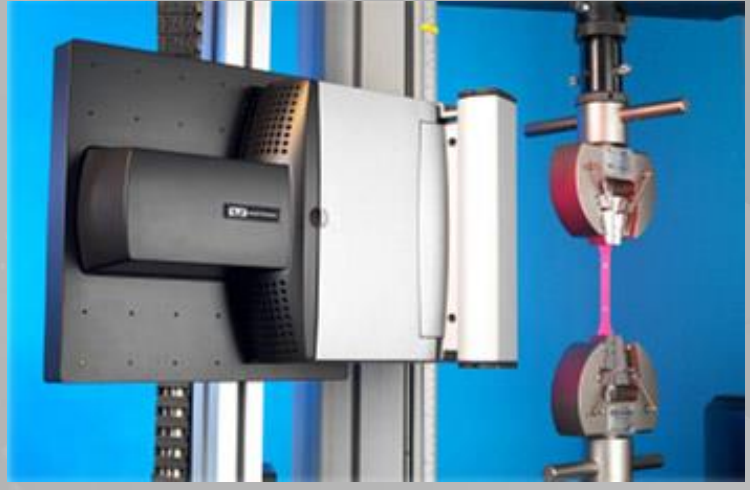
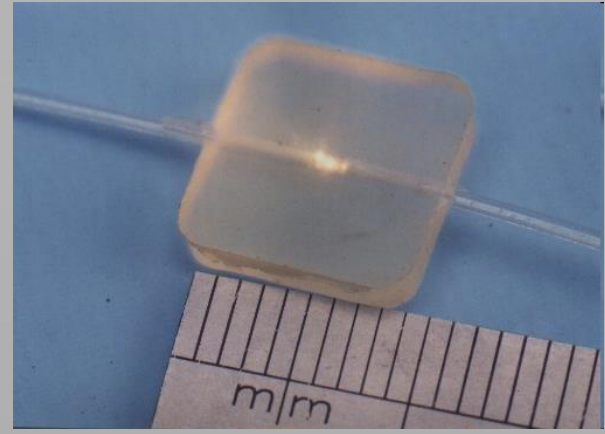



Dynamic Young's modulus

- ultrasonic waves

$$E_{\text{dyn}} = c^2 \cdot \rho_v$$



c ... sound velocity [$\text{m}^2 \cdot \text{s}^{-1}$]

ρ_v ... bulk density [$\text{kg} \cdot \text{m}^{-3}$]



Measuring of dynamic Young's modulus

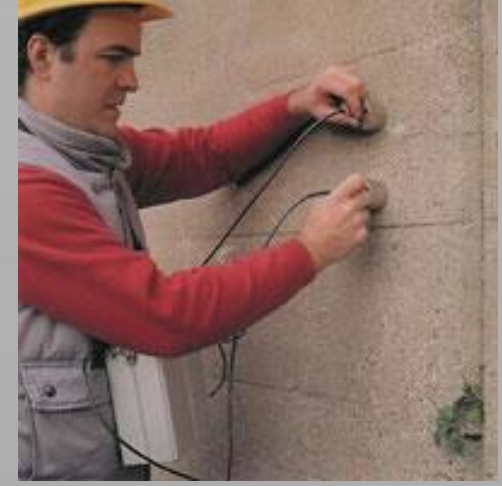



Elastic modulus is affected by:

- **temperature**
 - thermoplastics: with rising temperature E significantly decreases
 - concrete :
 - 20 °C - +70 °C - E constant
 - under -50 °C - ca. about 20 % higher
 - above 300 °C - ca. 50 % of initial value
- **moisture** – in porous materials



Young's modulus of some materials

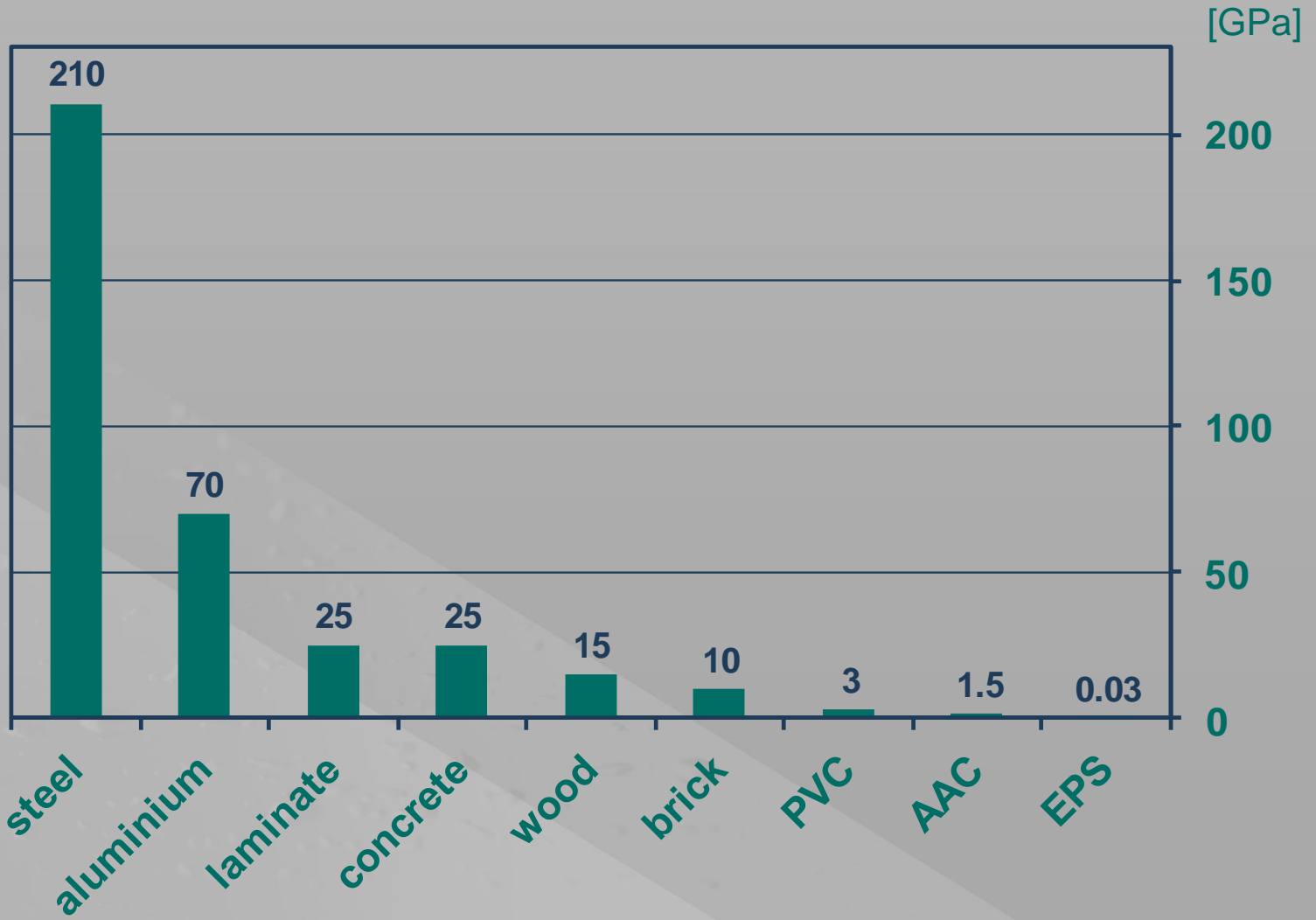



Building materials

Material	Young's modulus [GPa]
Diamond	1050-1200
Steel	210
Glass	50 -85
Aluminium and light alloys	65 -73
Brass and bronze	103-124
Concrete	15 - 60
Ceramic brick	8 - 12
Wood	7 -18
Glass laminate	10 - 30
Thermosets	4 - 13
Thermoplastics solid	0,1 - 4
Thermoplastics foamed	0,02 – 0,3
Rubber	0,002 –0,005

**Department of Materials Engineering
and Chemistry**

Faculty of Civil Engineering



Building materials



Ductility

- percentage elongation after tensile test

$$A(\delta) = \frac{L_u - L_0}{L_0} = \frac{\Delta L}{L_0}$$

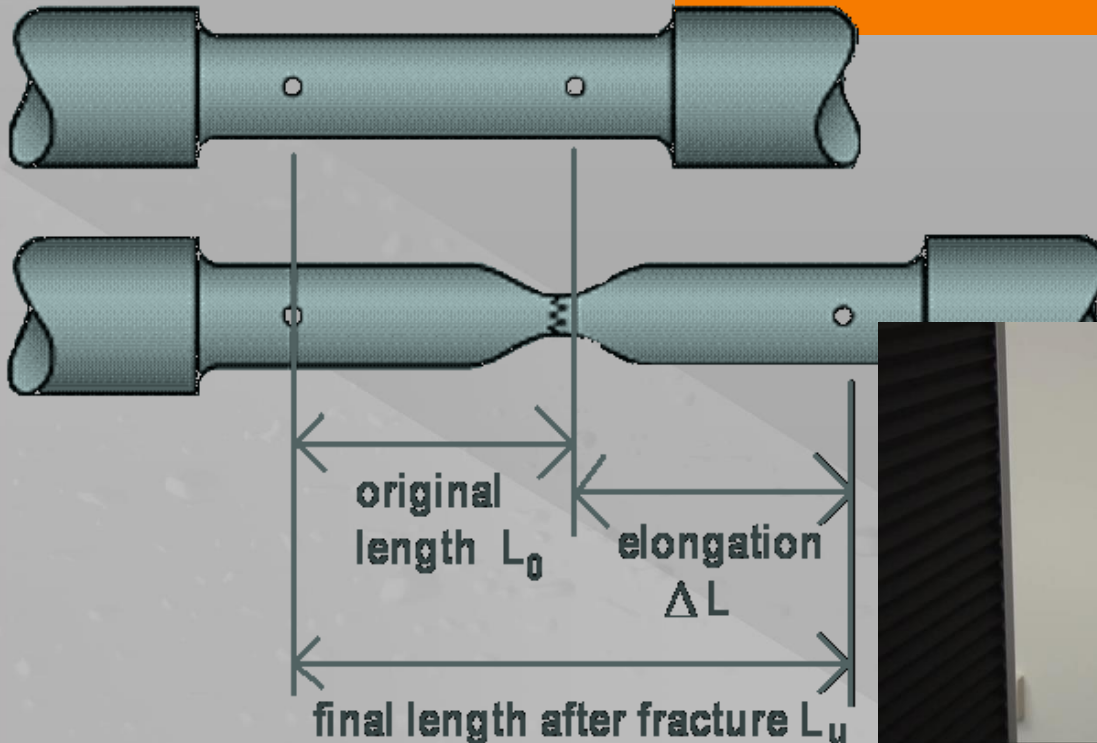



Reduction of area

- change of cross sectional area as a percentage of the original cross-sectional area

$$Z(\psi) = \frac{S_0 - S_u}{S_0}$$

S_0 original cross-sectional area before testing

S_u minimal cross-sectional area after failure

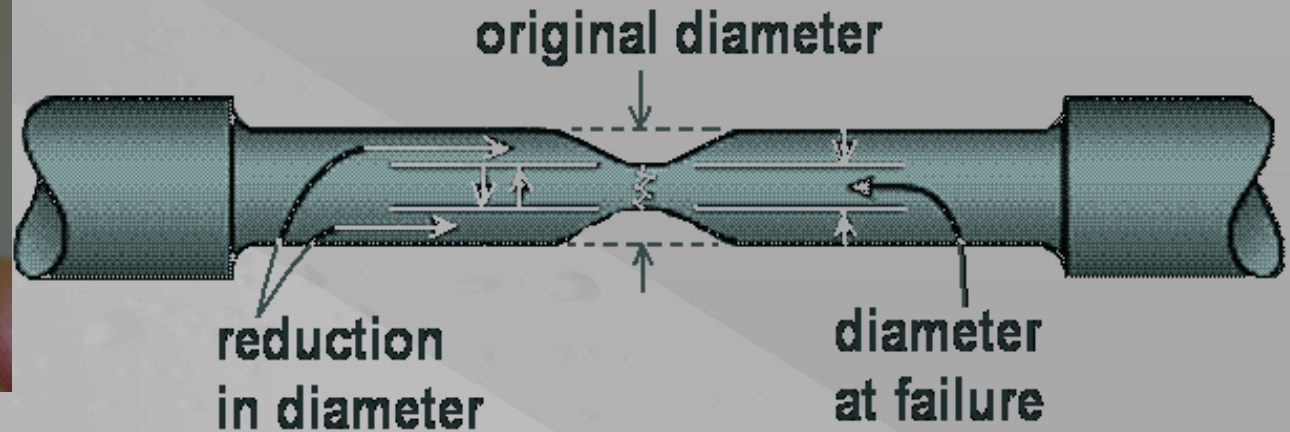



Brittle x tough materials

- **brittle** material, subjected to stress, breaks without significant deformation
- **tough** material deforms plastically and absorbs energy before fracture

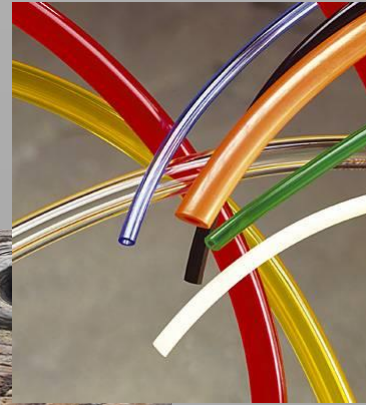
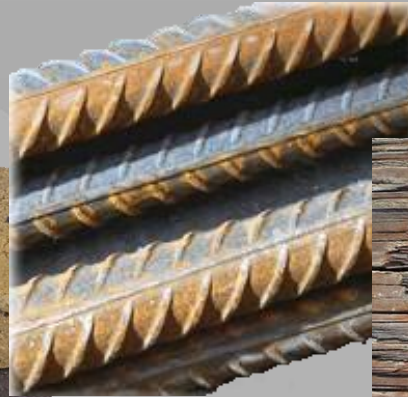
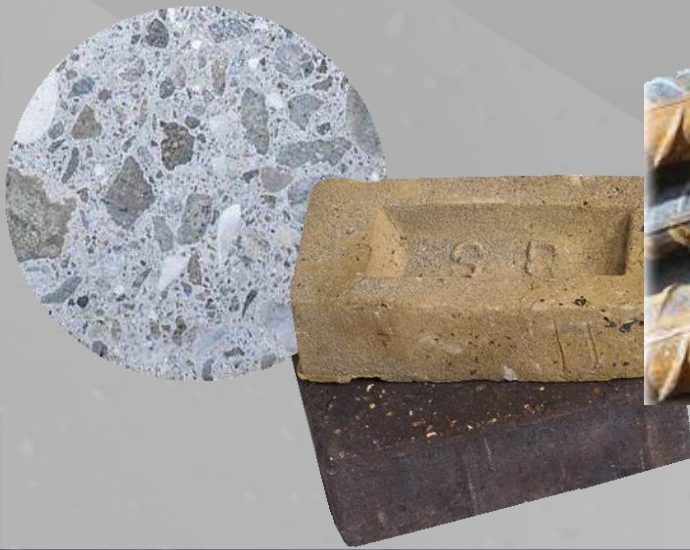



Toughness

- the amount of energy per volume that a material can absorb before rupturing
- units: kJ/m^3

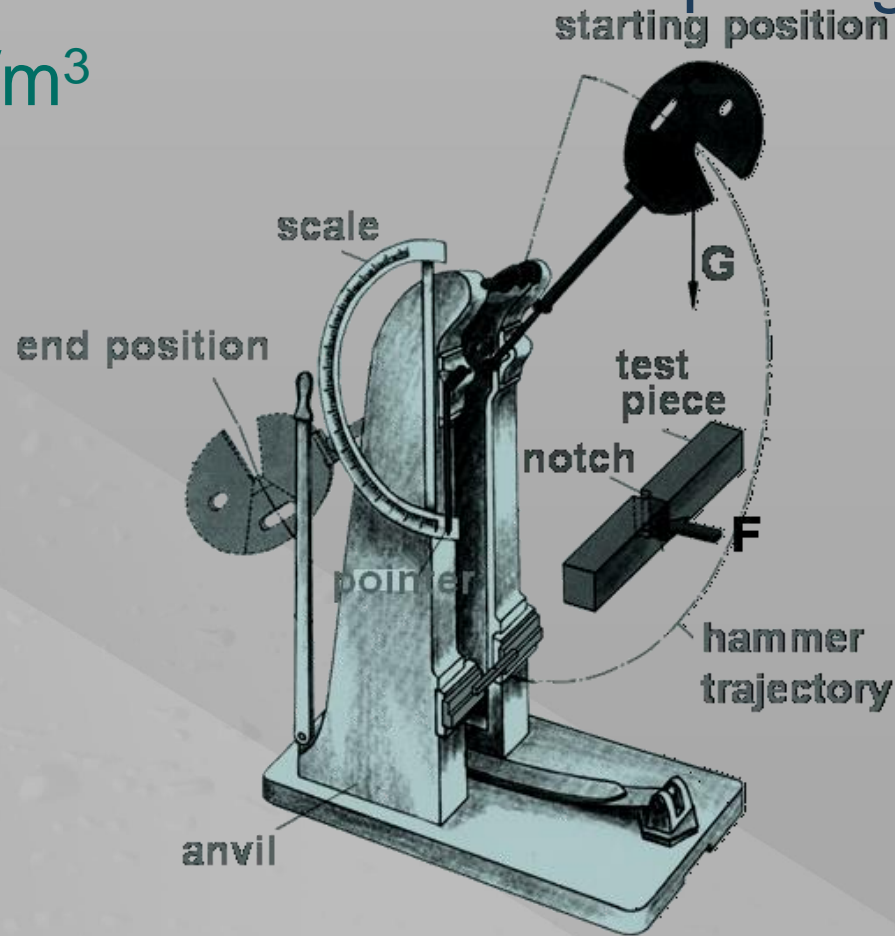



Test of toughness

- impact toughness
 - Charpy, Izod test
- notch toughness
(ability to absorb energy in the presence of a flaw)

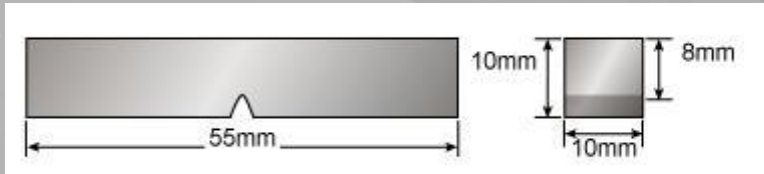



Charpy impact test





Brittleness

- tendency of a material to fracture or fail upon the application of a relatively small amount of force, impact, or shock
- opposite of toughness
- no numerical value



Rough criterion for brittle materials:
compressive strength : tensile strength
> 8 : 1

**Department of Materials Engineering
and Chemistry**

Faculty of Civil Engineering



Building materials



Hardness

- defines the materials resistance to penetration
- depends on temperature and moisture
- Methods:
 - **scratch hardness**
 - **indentation hardness**
 - **rebound hardness**

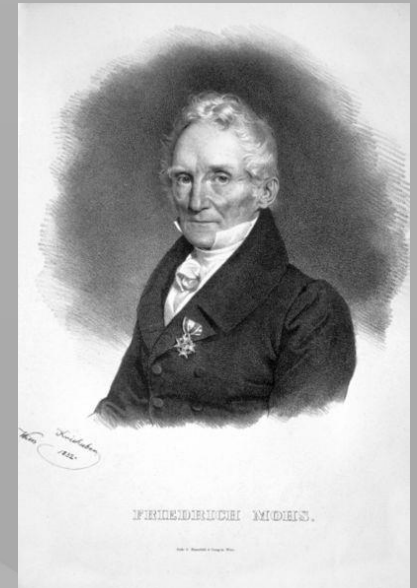



Scratch h. – Mohs scale

1. talc
2. gypsum
3. calcite
4. fluorite
5. apatite
6. feldspar (orthoclase)
7. quartz
8. topaz
9. corundum
10. diamond



- used for minerals



Indentation h. – Vickers test

- indenter: diamond point with a 136° point angle
- abbreviation **VHN**
- metals, hard materials



$$HV = 0,102 \times \frac{2F \sin \frac{136^\circ}{2}}{d^2} = 0,1891 \frac{F}{d^2}$$

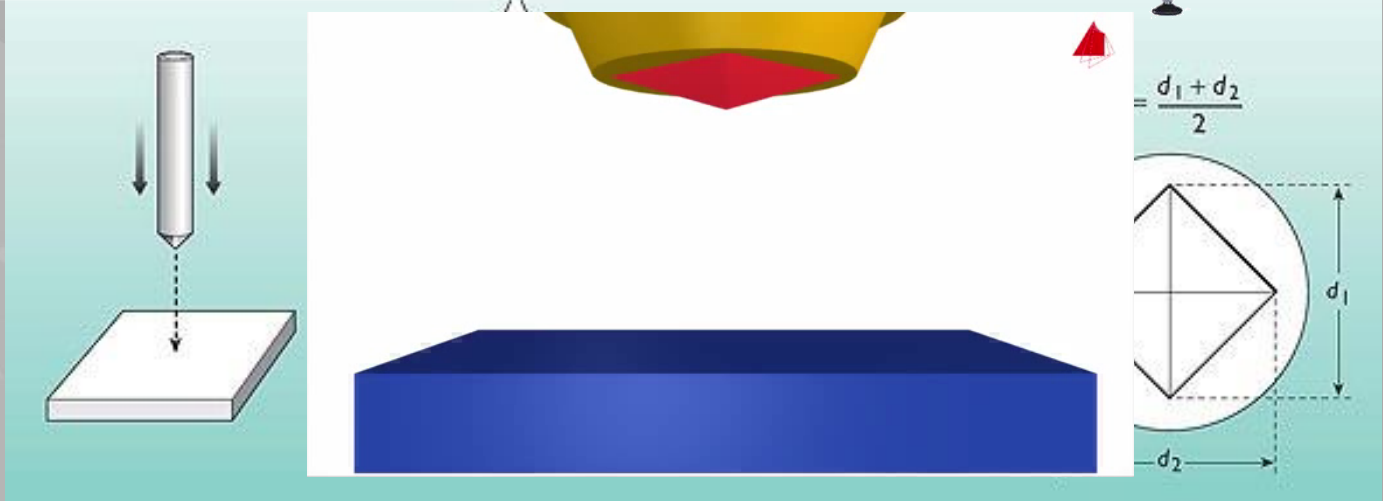



Indentation h. – Brinell test

- indenter: steel (tungsten) ball (10 mm \varnothing)
- abbreviation: **HBW, (HBS)**
- metals, wood, hard polymers

$$HB = 0,102 \frac{2F}{\pi \cdot D \cdot (D - \sqrt{D^2 - d^2})}$$

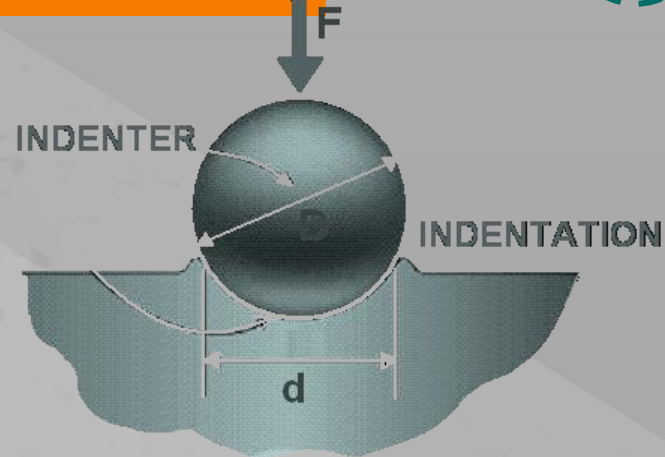



Indentation h. – Rockwell test

- diamond cone
- abb.: **HR**(A,B,C..G)
- depth of indentation
- metals

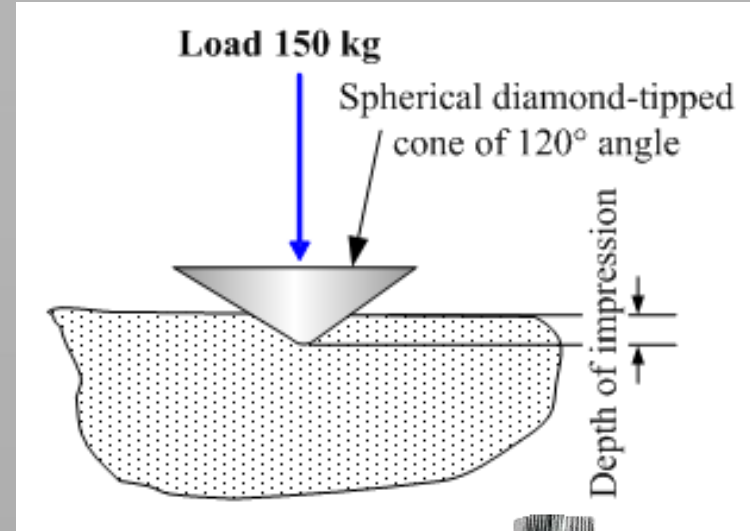

Shore durometer

- spring+ steel rod
- abb.: **SH**
- polymers, elastomers, rubber





Hardness conversion

- indicative only

Hardness Conversion

Convert From

Rockwell B Hardness (HRB)
 Rockwell C Hardness (HRC)
 Vickers Hardness (HV)
 Knoop Hardness (HK)
 Scleroscope Hardness (HS)

Rockwell C Hardness (HRC)

Brinell Hardness (HB)

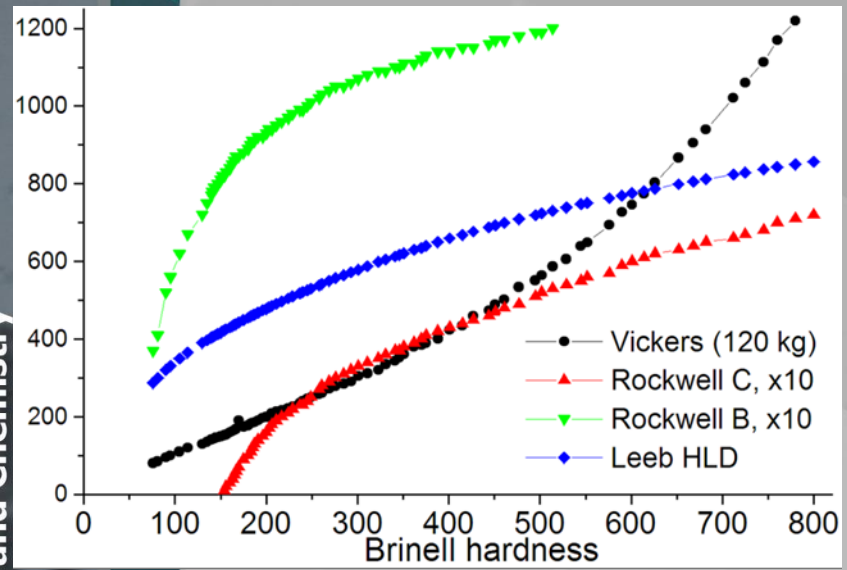

HARDENED STEEL AND HARD ALLOYS

Rockwell*				Superficial			Vickers	Knoop	Brinell	Tensile Strength	Micro-ficial
C	A	D	G	15-N	30-N	45-N	HV	HK	HB	KSI	WMN
150 kg Brale*	60 kg Brale	100 kg Brale	150 kg 1/16" ball	15 kg N Brale	30 kg N Brale	45 kg N Brale	10 kg	500 gm and over	3000 kg 10 mm ball	1000 lbs/sq in	1000 gm
80	92.0	86.5	▲	96.5	92.0	87.0	1865	-	▲	▲	-
79	91.5	85.5	▲	96.3	91.5	86.5	1787	-	▲	▲	-
78	91.0	84.5	▲	96.0	91.0	85.5	1710	-	▲	▲	-
77	90.5	84.0	▲	95.8	90.5	84.5	1633	-	▲	▲	-
76	90.0	83.0	▲	95.5	90.0	83.5	1556	-	▲	▲	-
75	89.5	82.5	▲	95.3	89.0	82.5	1478	-	▲	▲	-
74	89.0	81.5	▲	95.0	88.5	81.5	1400	-	NOTE 1	NOTE 2	-
73	88.5	81.0	▲	94.8	88.0	80.5	1323	-	▲	▲	-
72	88.0	80.0	▲	94.5	87.0	79.5	1245	-	▲	▲	-
71	87.0	79.5	▲	94.3	86.5	78.5	1160	-	▲	▲	-
70	86.5	78.5	▲	94.0	86.0	77.5	1076	972	▲	▲	953
69	86.0	78.0	▲	93.5	85.0	76.5	1004	946	▲	▲	949
68	85.6	76.9	▲	93.2	84.4	75.4	940	920	▲	▲	945
67	85.0	76.1	▲	92.9	83.6	74.2	900	895	▲	▲	942
66	84.5	75.4	▲	92.5	82.8	73.3	865	870	NA	▲	938
65	83.9	74.5	▲	92.2	81.9	72.0	832	846	739	▲	934
64	83.4	73.8	▲	91.8	81.1	71.0	800	822	722	▲	930
63	82.8	73.0	▲	91.4	80.1	69.9	772	799	706	▲	926
62	82.3	72.2	▲	91.1	79.3	68.8	746	776	688	▲	922
61	81.8	71.5	▲	90.7	78.4	67.7	720	754	670	▲	917
60	81.2	70.7	▲	90.2	77.5	66.6	697	732	654	NA	913
59	80.7	69.9	▲	89.8	76.6	65.5	674	710	634	351	909
58	80.1	69.2	▲	89.3	75.7	64.3	653	690	615	338	904
57	79.6	68.5	▲	88.9	74.8	63.2	633	670	595	325	900
56	79.0	67.7	▲	88.3	73.9	62.0	613	650	577	313	896
55	78.5	66.9	▲	87.9	73.0	60.9	595	630	560	301	891
54	78.0	66.1	▲	87.4	72.0	59.8	577	612	543	292	887
53	77.4	65.4	▲	86.9	71.2	58.6	560	594	525	283	883
52	76.8	64.6	▲	86.4	70.2	57.4	544	576	512	273	879
51	76.3	63.8	▲	85.9	69.4	56.1	528	558	496	264	874
50	75.9	63.1	▲	85.5	68.5	55.0	513	542	481	255	870
49	75.2	62.1	▲	85.0	67.6	53.8	498	526	469	246	865
48	74.7	61.4	▲	84.5	66.7	52.5	484	510	455	238	861
47	74.1	60.8	▲	83.9	65.8	51.4	471	495	443	229	856



Indentation h.–**POLDI hammer**

- Comparison of the indentation size of tested material and reference material with known hardness





Rebound h. – Schmidt hammer

- measures the rebound of a spring-loaded mass impacting against the surface of the sample

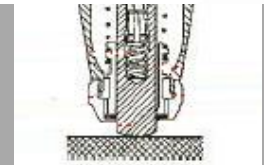
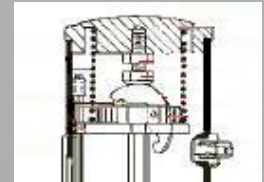



Correlation between Schmidt rebound number and the compressive strength

- the rebound value can be used to determine the compressive strength (by reference to the conversion chart)

Depends on:

- orientation of the hammer
- water content

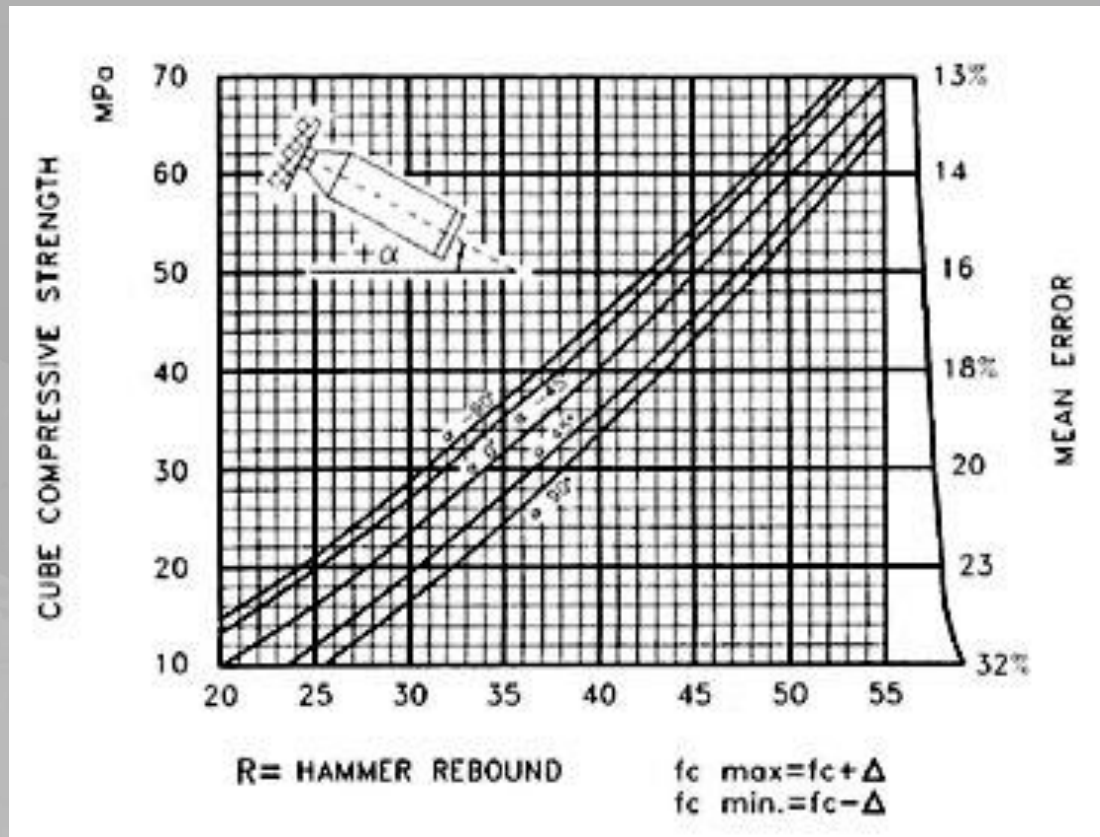

**Department of Materials Engineering
and Chemistry**

Faculty of Civil Engineering



Building materials



Fatigue



- fatigue occurs when a material is subjected to repeated loading and unloading
- cyclic stress causes the decrease of the strength
- typical for metals



Fatigue limit (strength) = the amplitude (or range) of cyclic stress that can be applied to the material without causing fatigue failure



Fatigue

- if the loads are above a certain threshold, microscopic cracks will begin to form
- after reaching critical size, and the structure will suddenly (without warning) fracture
- the shape of the structure affect the fatigue life (square holes, sharp corners)
- the greater the applied stress range, the shorter the life
- damage is cumulative, materials do not recover when rested
- f. is influenced by a variety of factors (temperature, surface finish, microstructure, presence of oxidizing or inert chemicals, residual stresses, etc.)



Endurance limit

- some materials (ferrous and titanium alloys) have a distinct limit below which there appears to be no number of cycles that will cause failure
- some structural metals (aluminium, copper) do not have a distinct limit and will eventually fail even from small stress amplitudes

S-N (Wöhler) curves

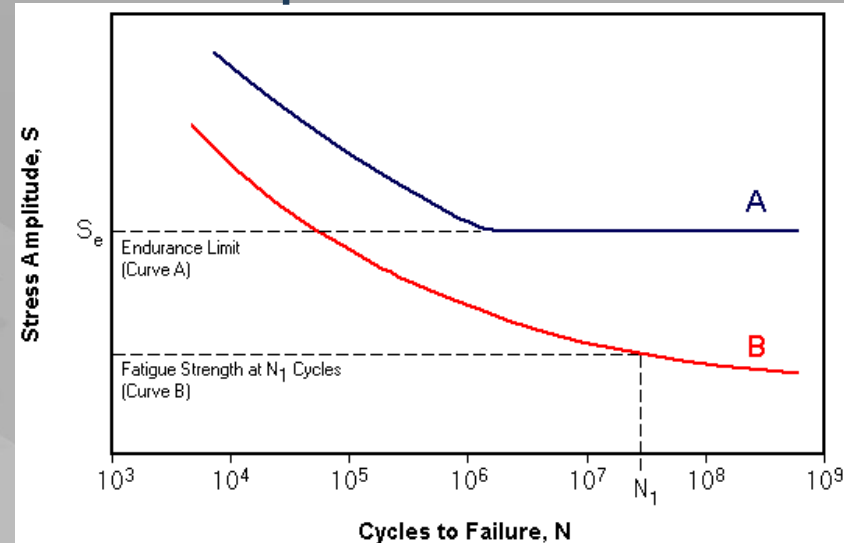



Fatigue cracks

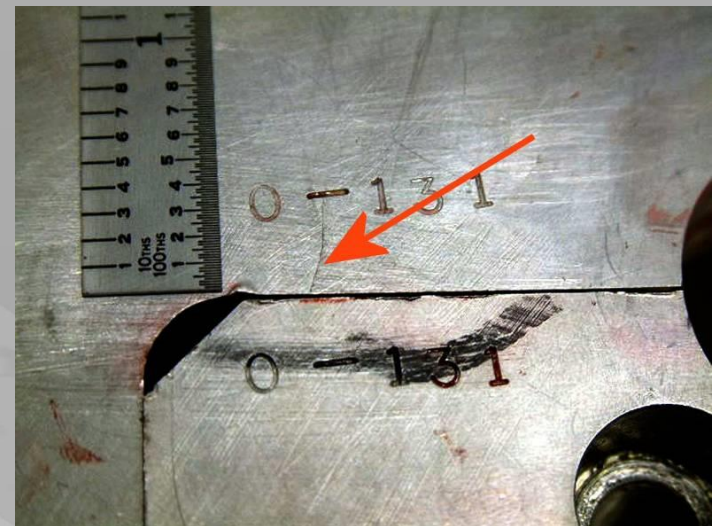
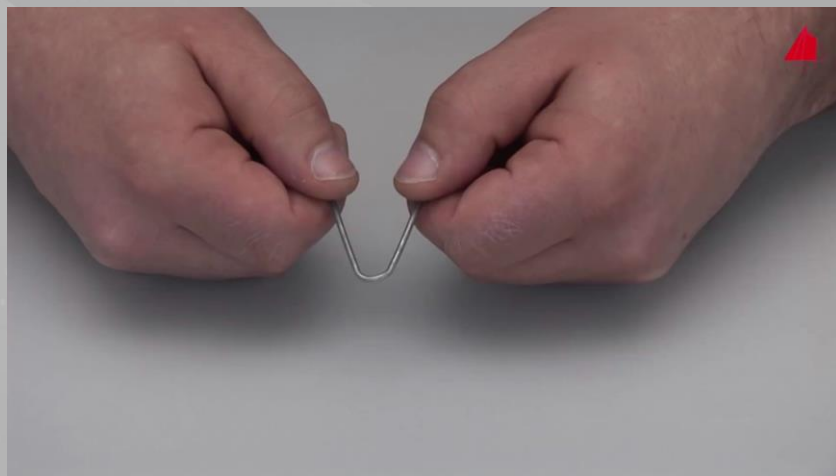
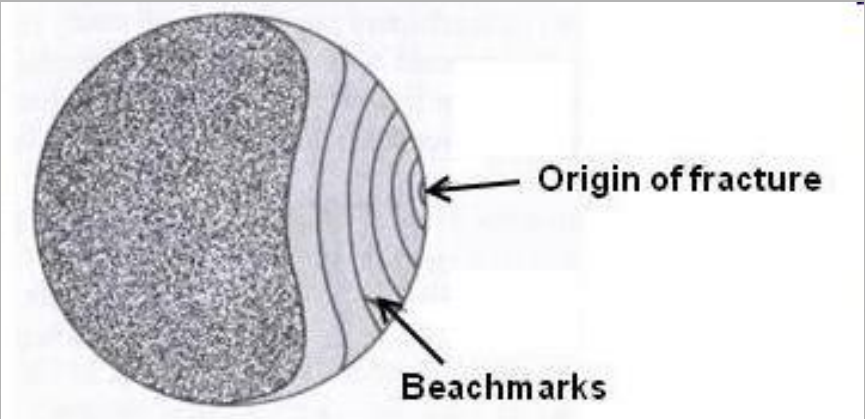



Fatigue testing

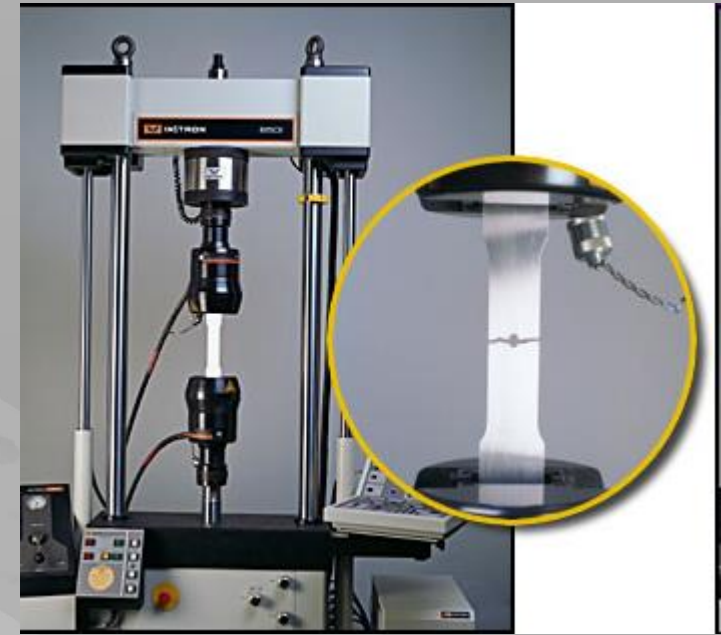
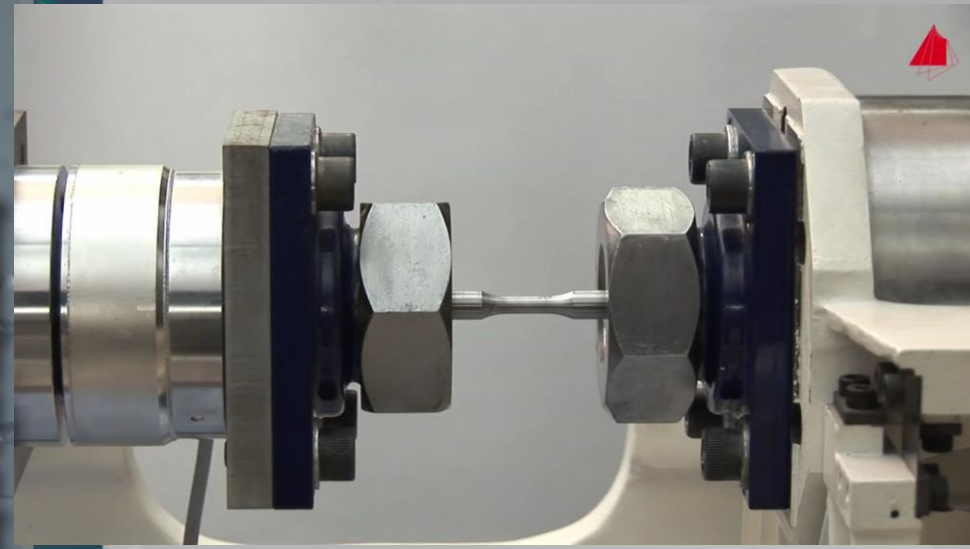
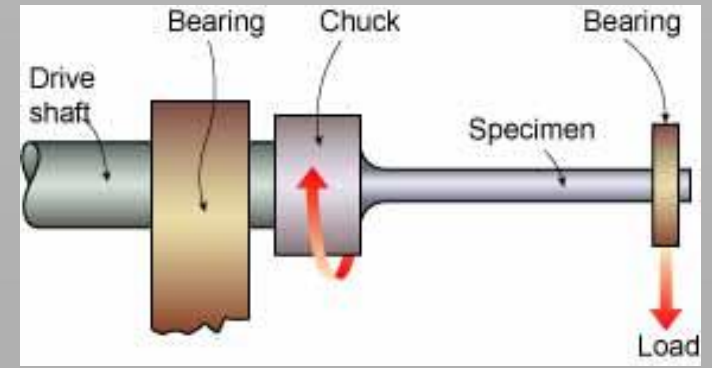



Infamous fatigue failures

- **Boston Molasses Disaster**
(USA, Boston, 1919)





Infamous fatigue failures

- Alexander L. Kielland oil platform capsized (Norway, 1980)

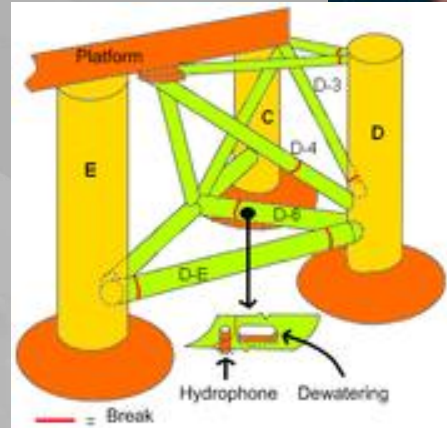



Infamous fatigue failures

- InterCity expres (Germany, Eschede, 1998)
 - fatigue crack in one wheel

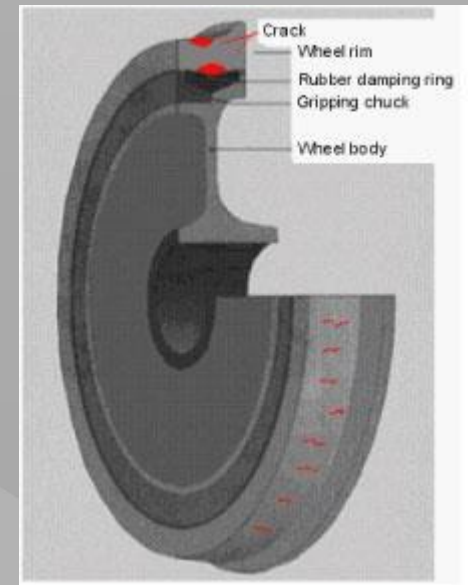
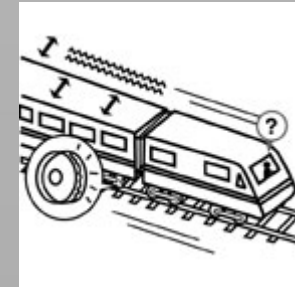



Dynamic strength

- Tacoma narrows bridge (USA, Washington, 1940)





Abrasion resistance

- ability of a surface to resist being worn away by rubbing or friction
- coatings, paints, floor surfaces, pipes





Abrasion resistance tests

- usually measured as a loss percentage based on original weight
- big scale of different tests

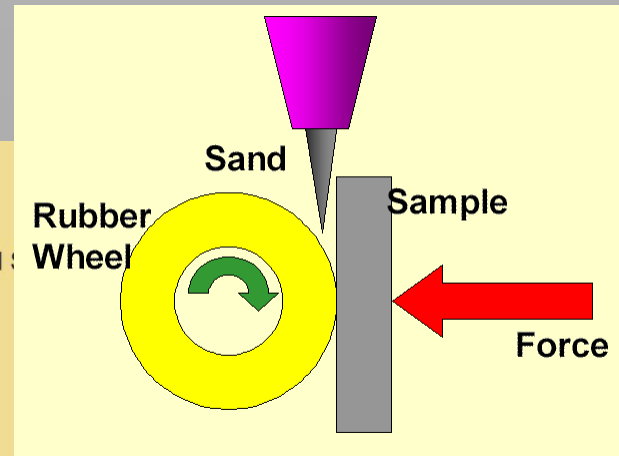
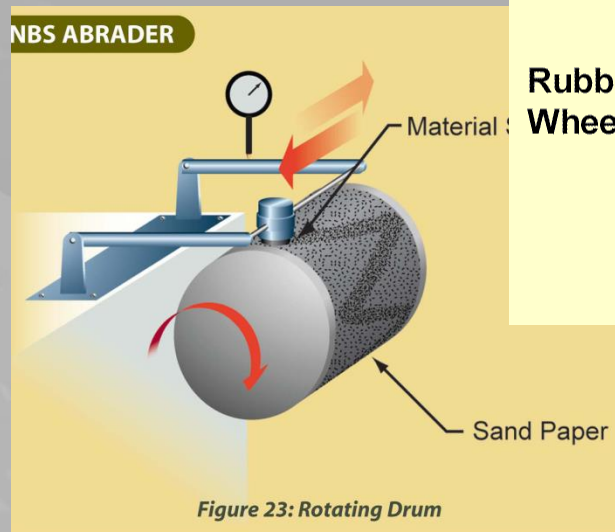
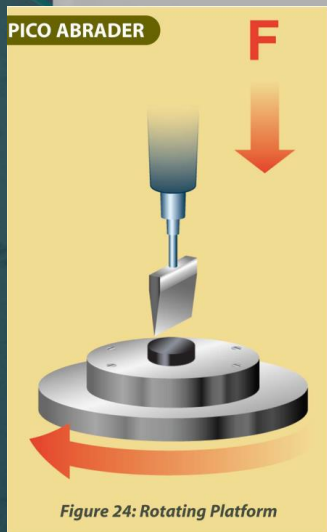



Abrasion resistance tests

Taber abrader

- thickness loss after defined number of rotations using standardized wheel and defined load

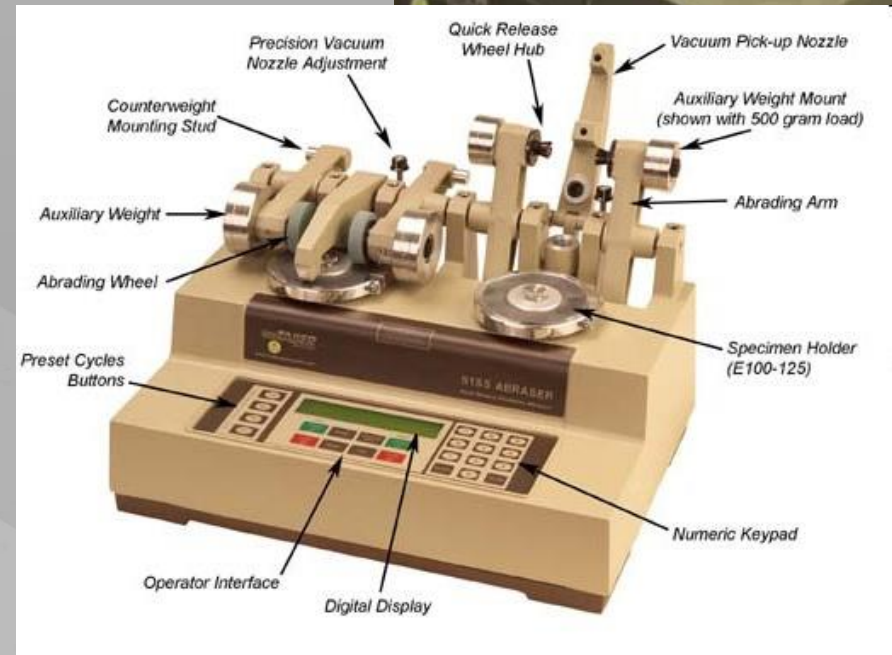
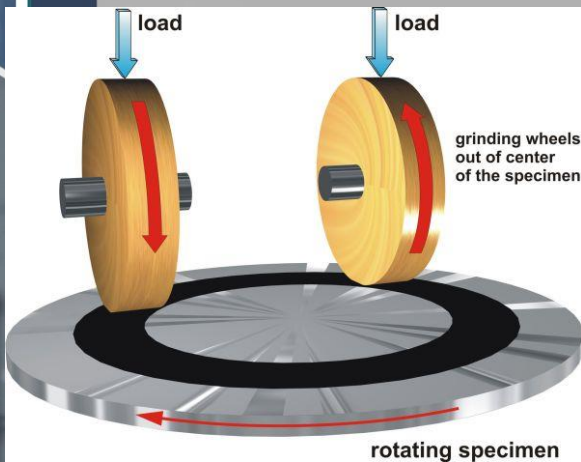



Comparative Abrasion Resistance of Various Polymers

Material	Weight Loss (mg)
thermoplastic urethane	0.4-3.2
ionomer	12
nylon 6/10	16
nylon 11	24
HDPE	29
polytetrafluorethylene	42
nitrile rubber	44
nylon 6,6	58
LDPE	70
rigid PVC	122
natural rubber (tread formulation)	146
SBR (premium tread formulation)	177
SBR (tread formulation)	181
plasticized PVC	187
butyl rubber	205
ABS	275
neoprene (polychloroprene)	280
polystyrene	324

Taber abrasion, CS17 wheel, 1000 gm weight, 5000 revolutions
Ref: Handbook of Thermoplastic Elastomers, Litton Educational Publishing,



Abrasion resistance tests

Amsler/Böhme test

- a specimen is subjected to stress by grinding
- the abrasive grit accumulating from this is indicated as loss of volume or thickness (abrasive loss) per test area 50 cm^2

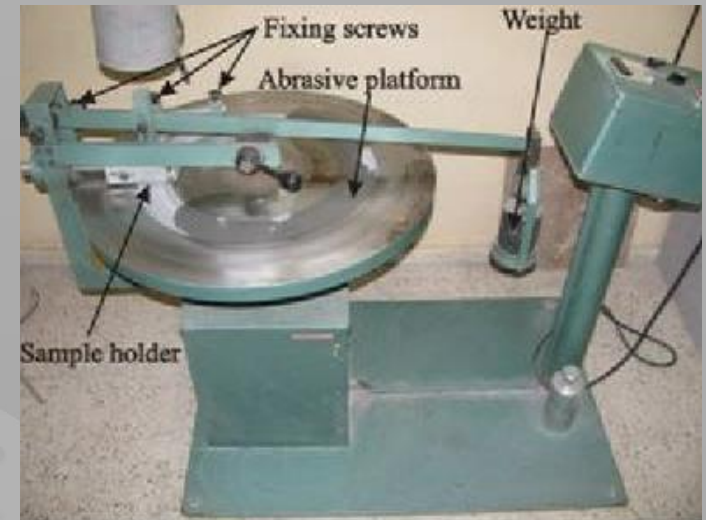
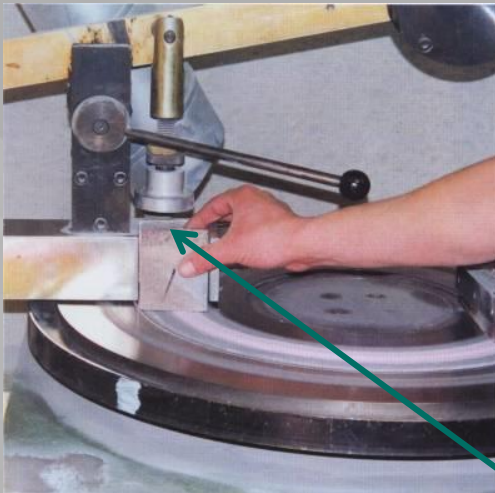

test area $7,07 \times 7,07 \text{ cm}$



Abrasion resistance - standards (Amsler / Böhme)

- EN 1338, 1339, 1340 – concrete pavings
- EN 14157 – natural stones
- EN 13 892-3 – screeds













	abrasion resistance					cm ³ /50 cm ²
	100	80	60	40	20	
Granite + Tonalite						
Syenite + Gabbro						
Lava						
Vulcanic tuff						
Sandstone						
Clay shale						
Limestone compact						
Limestone porous						
Marble						
Serpentine						
Paragneiss						
Quarzite						

Fig. 3.70 Böhme test abrasion values for different rock types including their range of dispersion (modified after Müller 2001). Note, higher values (from right to left) indicate a rock having a lower abrasion resistance, lower values indicate a higher abrasion resistance



Underwater Method

- **ASTM C1138: Standard Test Method for Abrasion Resistance of Concrete**



Sample Before Test



Set-up sample for apparatus



Test in progress – Between Cycles

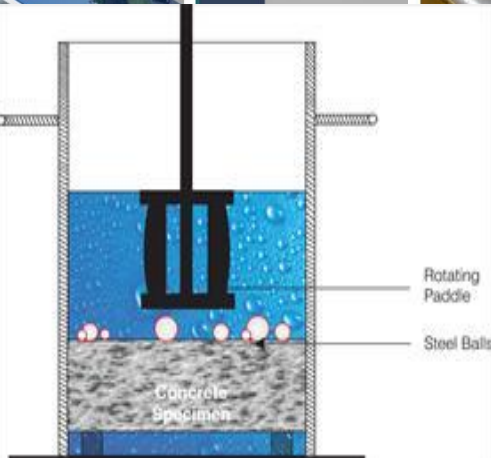

Sample removed from Apparatus – Between Cycles



Sample Between Cycles



Sample After 6 Cycles (Each Cycle is 12 Hours)



Adhesion and cohesion

- **adhesion** – state in which two surfaces are held together by interfacial effects
- **cohesion** – ability of a material to maintain its strength when unconfined

adhesion < cohesion



Adhesion

- between two materials - in composites (steel + concrete, cement + aggregates...)

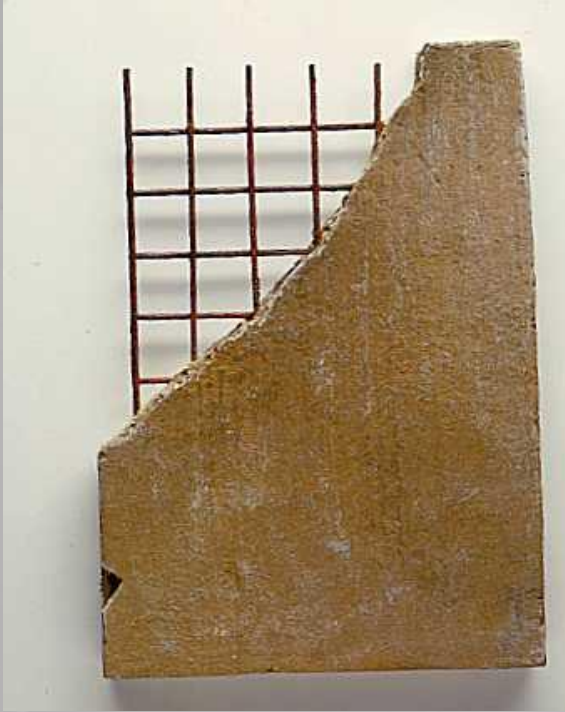



Adhesive strength

- between the upper layer and base (plasters, coatings..)





Pull-off test

- the circular pull-head plates are glued to the test material and upper layer is cut around them

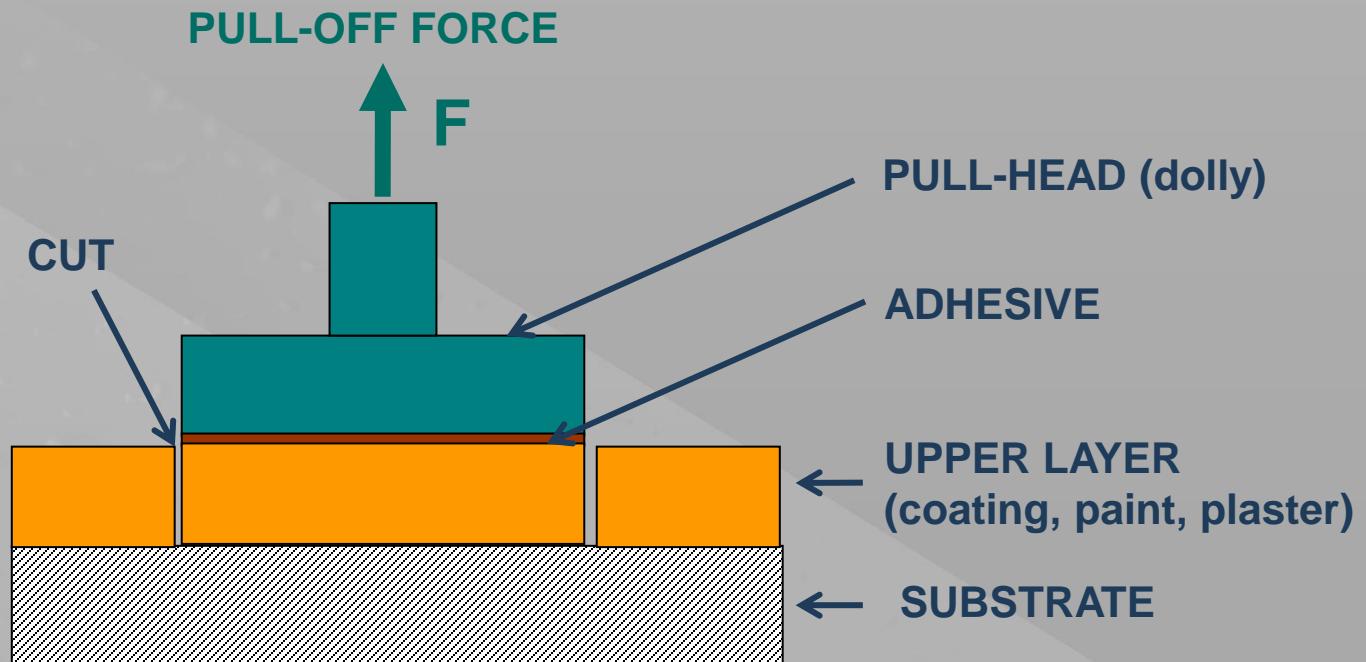



Pull-off test equipment



Pull-off Adhesion Testing
Instructional Video





Adhesive strength f_a

- test results:

$$f_u = \frac{F_u}{A}$$

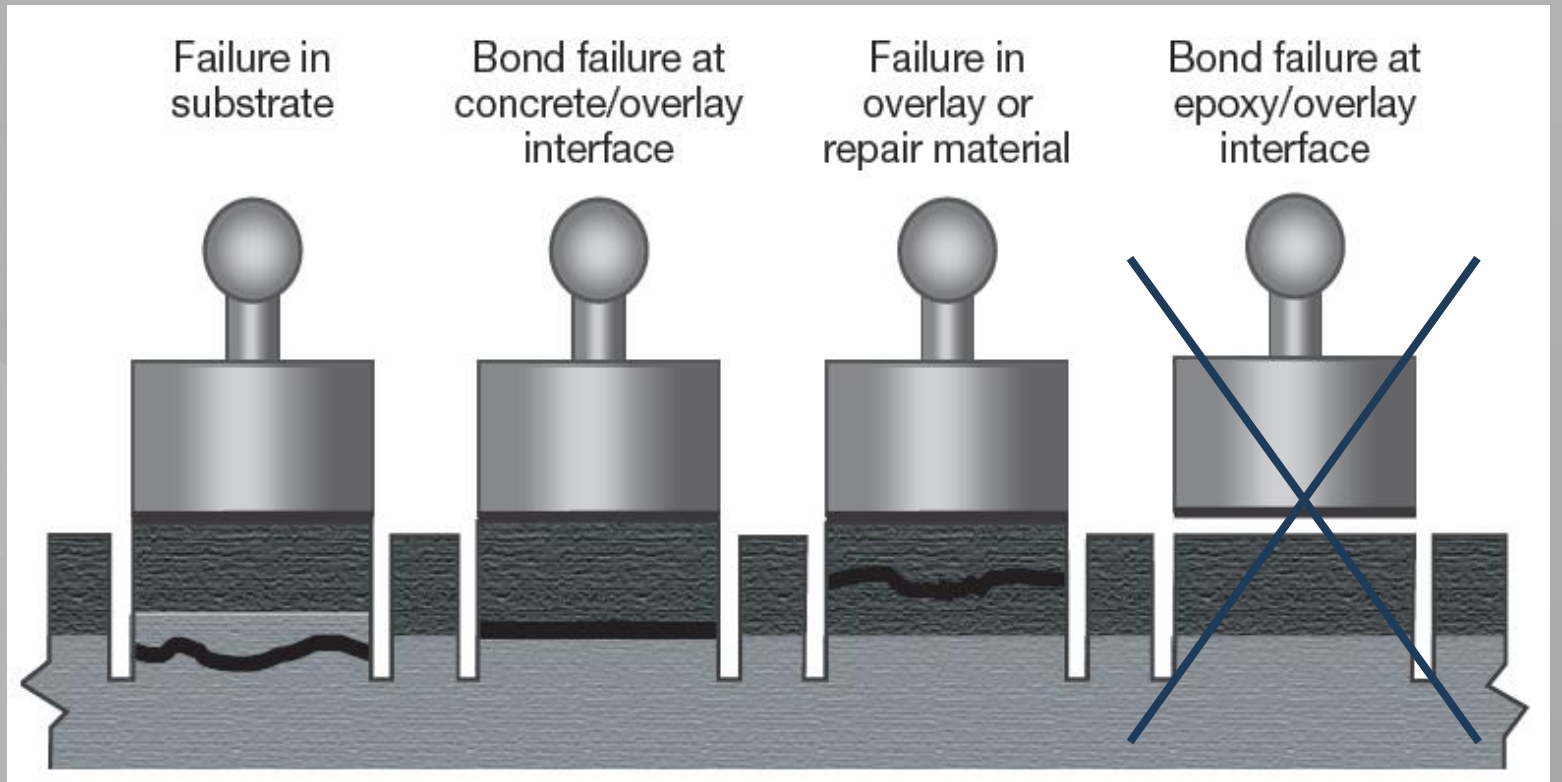

$f_a > f_u$

$f_a = f_u$

$f_a > f_u$

invalid result

**Department of Materials Engineering
and Chemistry**

Faculty of Civil Engineering



Building materials



Moisture (hygric) properties





Definitions

- **Moisture content** - amount of water contained in a material
- **Dampness** - presence of unwanted moisture in the structure of a building,
- **Humidity** - amount of water vapor in the air
- **Hygric** - relating to moisture



Moisture content

- amount of water contained in a material, which can be removed by drying
- any porous material in the construction is not quite dry !





Moisture sources



1. Leaking roofs and ice dams
2. High humidity in bathrooms and kitchens
3. Leaking pipes
4. Flooding in basement
5. Pooling water at foundation
6. Condensation on windows and exterior walls





Building materials



Source	Moisture Production Liters per Day
People (Evaporation per Person)	0.75 (Sedate), 1.2 (Avg.) to 5 (Heavy Work)
Humidifier	2-20+
Hot Tub, Whirlpool	2-20+
Firewood, per Cord	1-3
Washing Floors etc.	0.2
Dishwashing	0.5
Cooking for Four	0.9 to 2 (3 with Gas Range)
Frost-Free Fridge	0.5
Typical Bathing/Washing per Person	0.2 to 0.4
Shower (ea.)	0.5
Bath (ea.)	0.1+
Unvented Gas Appliance	0.15 kg/kWh for Natural Gas, 0.10 kg/kWh for Kerosene
Seasonal Desorption (or New Materials)	3 - 8 Depends on the House Construction
Plants/Pets	0.2-0.5 (Five Plants or One Dog)



Moisture types

According time:

- **initial moisture** (natural, manufacturing)
- **storage moisture**
- **stabilized moisture** (constant - after longer period – ca 2 - 7 years)





Moisture content during time period

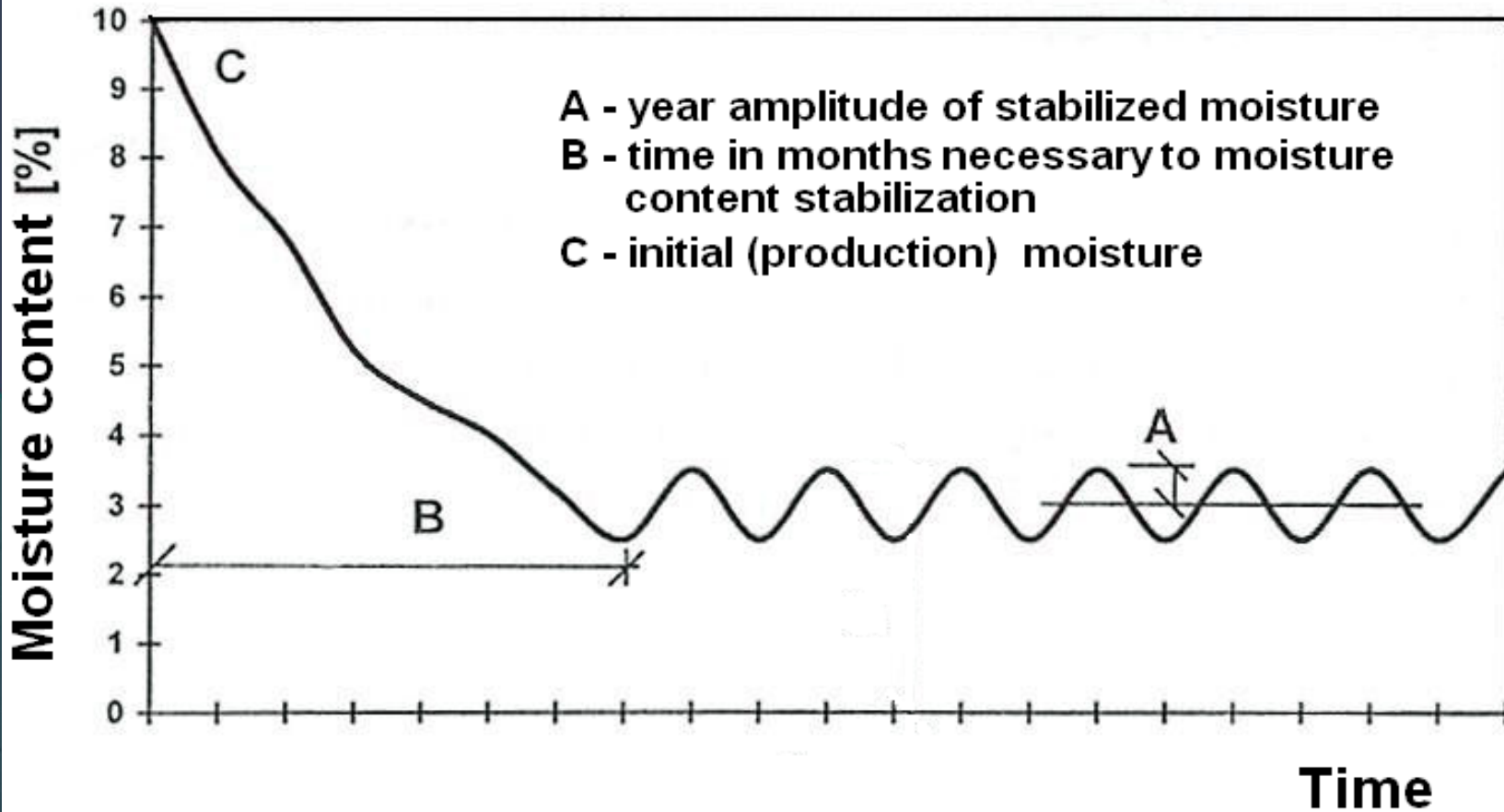



Gravimetric water content (Water content by mass)

$$w_m = \frac{m_{H_2O}}{m_D} = \frac{m_W - m_D}{m_D} (*100)$$

m_D mass of dry material

m_W mass of wet material

m_{H_2O} mass of water in material



Volumetric water content (Water content by volume)

$$w_v = \frac{V_{H_2O}}{V} = \frac{m_W - m_D}{\rho_{H_2O} * V} (*100)$$

- m_D mass of dry material
- m_W mass of wet material
- V_{H_2O} ... volume of water in material
- V volume of material



Maximal water content

- amount of water taken in by a material when immersed
 - material is saturated (fully soaked)
- volumetric water content
 - **0 - 100 %**
- gravimetric water content:
 - **could be higher than 100 %** (lightweight materials)

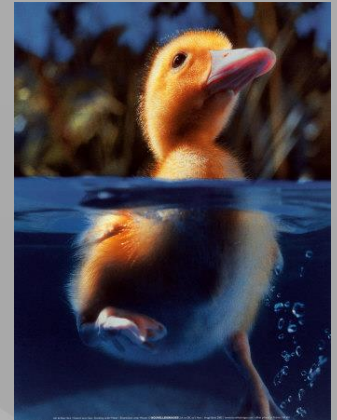



Maximal water content x porosity

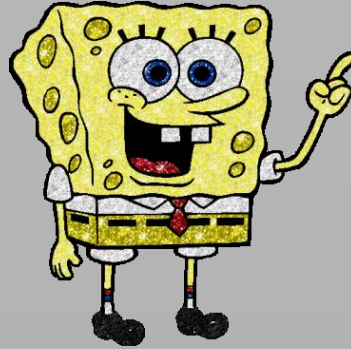

- when material is saturated, water fills up all **open pores** →
value of maximal volumetric water content
= value of open porosity

$$w_{\max} = p_{\text{open}}$$



Maximal water content

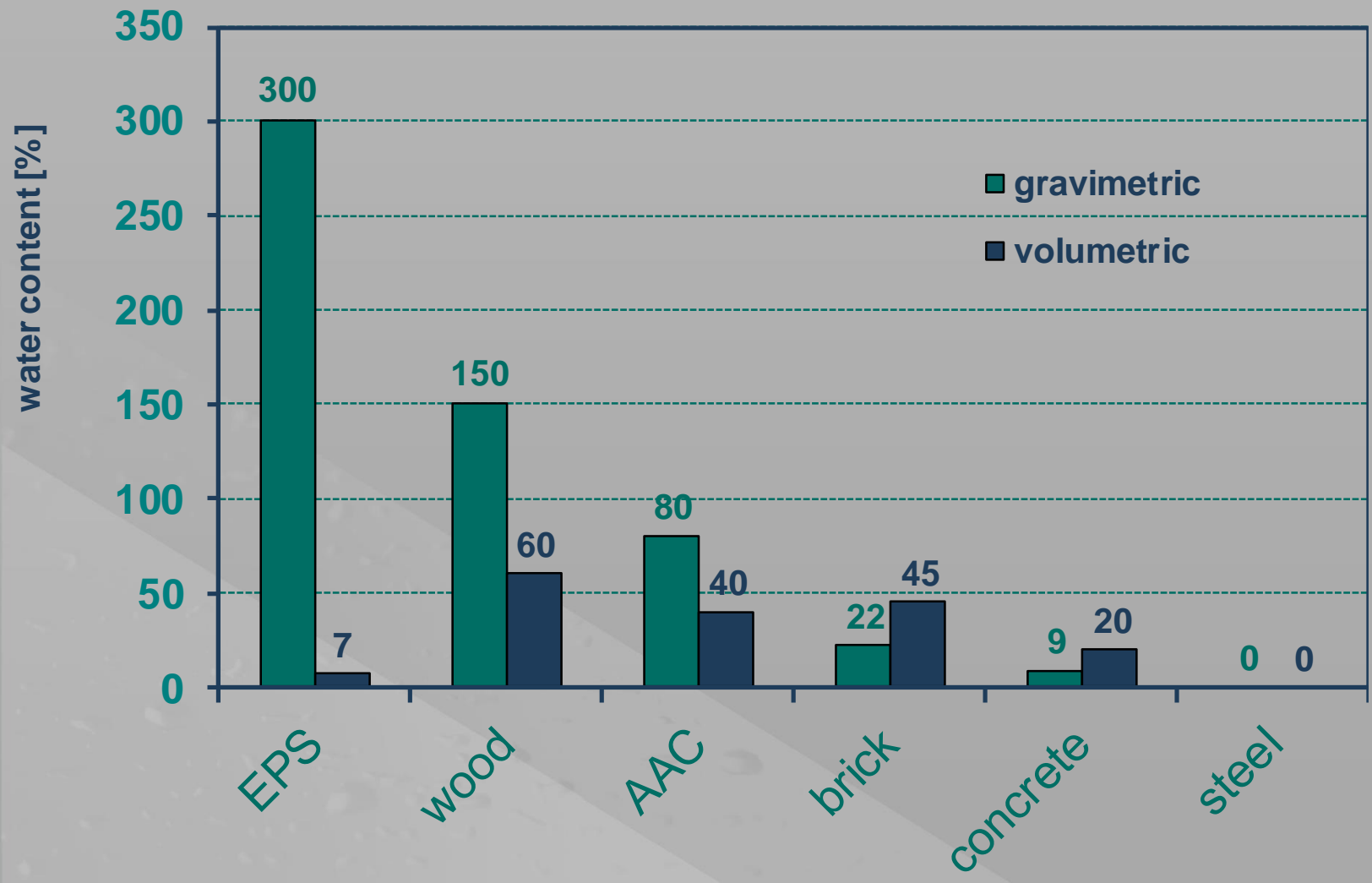



Capillarity

- ability of a liquid to flow in narrow spaces without the assistance of, and in opposition to external forces like gravity

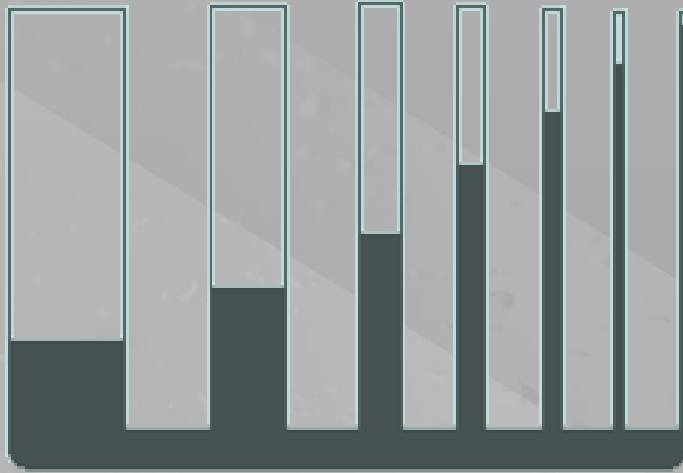



Capillarity in buildings

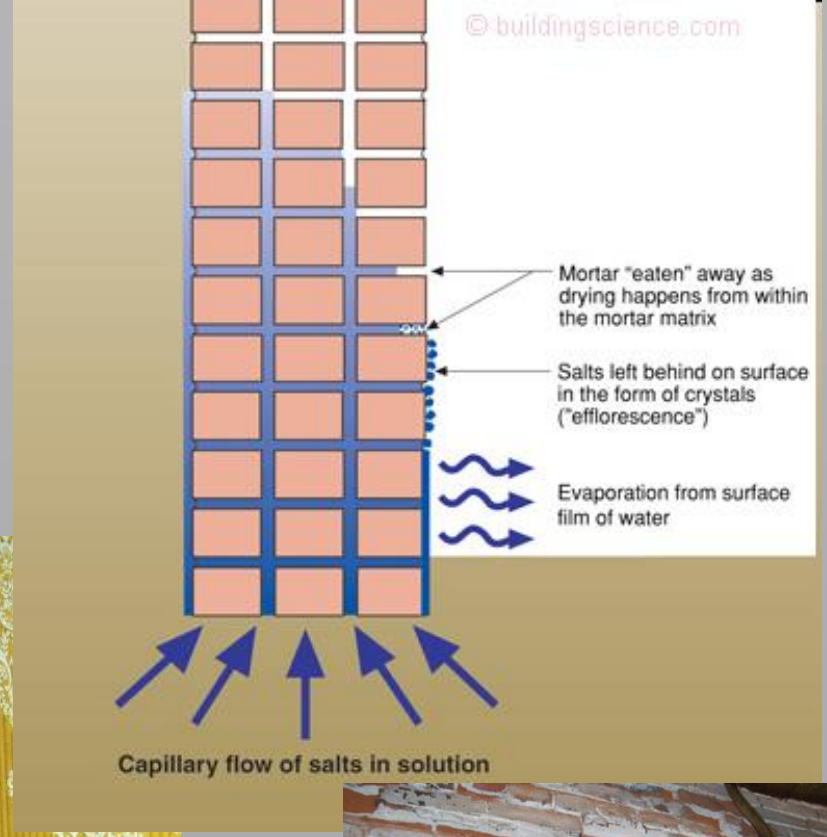



Capillary water absorption test

- the material is put into the low level of water (its sides are sealed) and increase of its mass is measured at given times

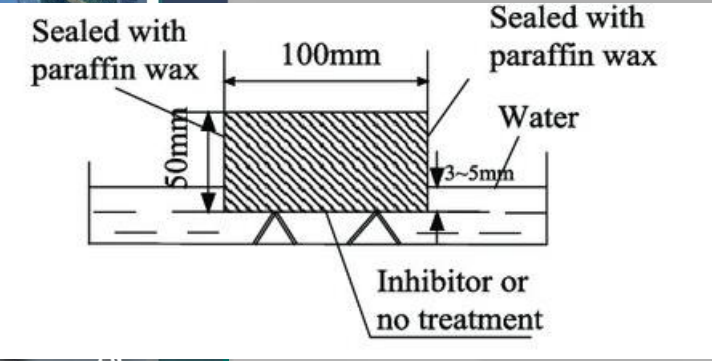
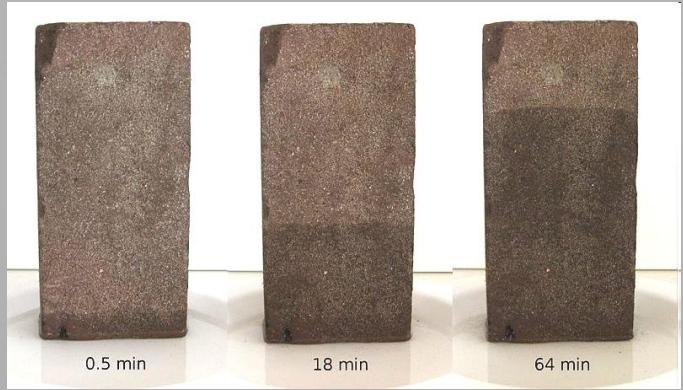

	Bulk density in dry state [kg/m ³]	Gravimetric capillarity [kg/m ³ after		
		2 hours	8 hours	24 hours
Foamed polystyrene	16	1,1	1,2	1,2
Foamed polyurethane	35	0,3	0,4	0,4
AAC	540	12,7	19,9	29,7



Sorption behavior

- ability of a hygroscopic material to absorb or release water vapor from or into the air until a **state of equilibrium** is reached

adsorption

(uptake of water vapor)

x

desorption

(water vapor release)





Equilibrium moisture content

- each material has typical **sorption isotherms**

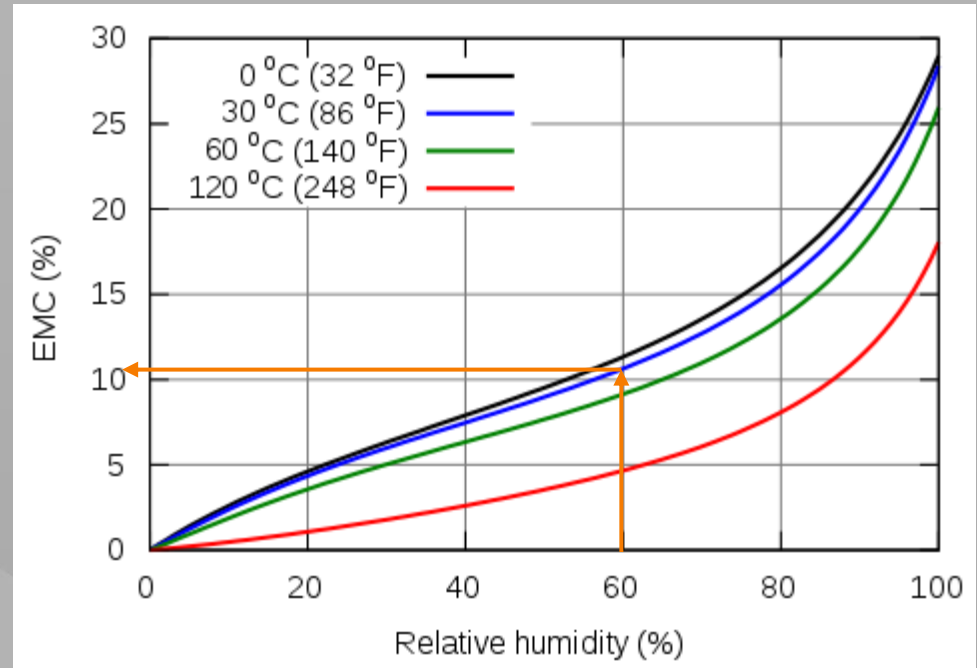

Depends on:

- air temperature, pressure and humidity
- pores sizes and shapes
- history



Sorption isotherms of some building materials

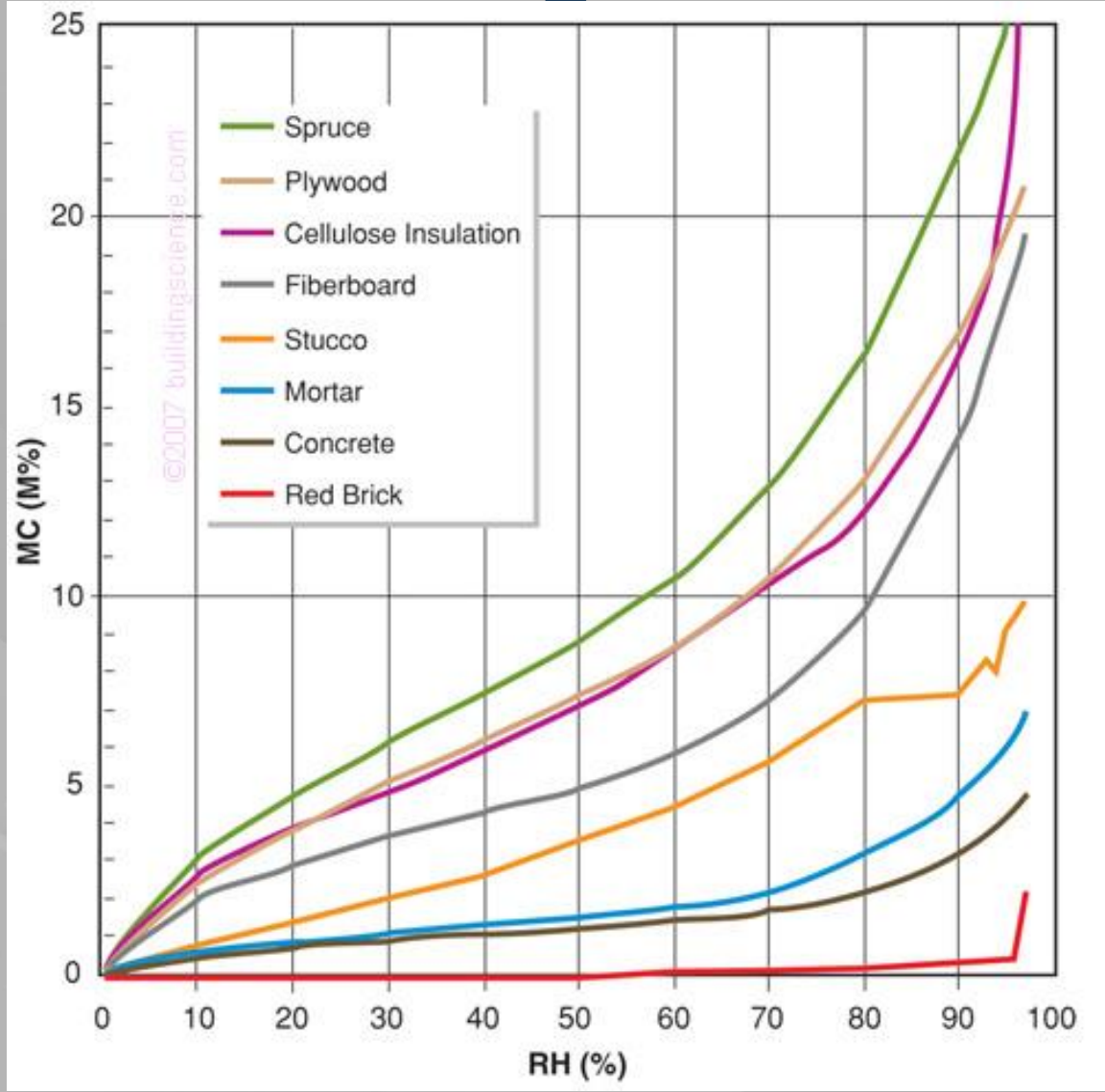



Sorption hysteresis

- desorption give higher equilibrium moisture contents than absorption at equal ambient climate conditions

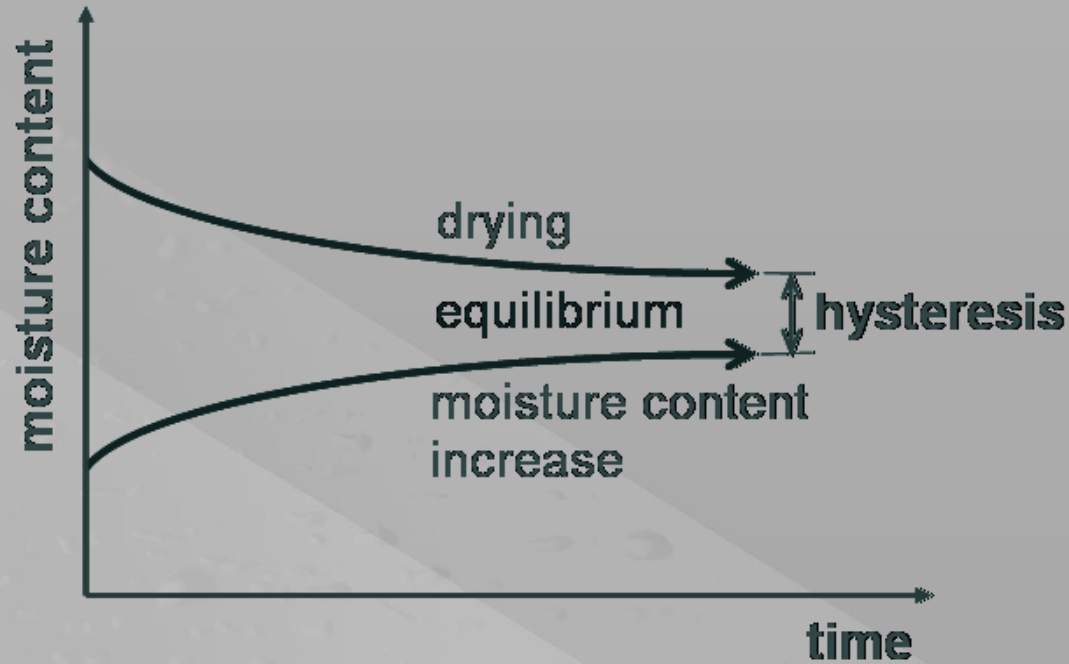



Sorption hysteresis curve

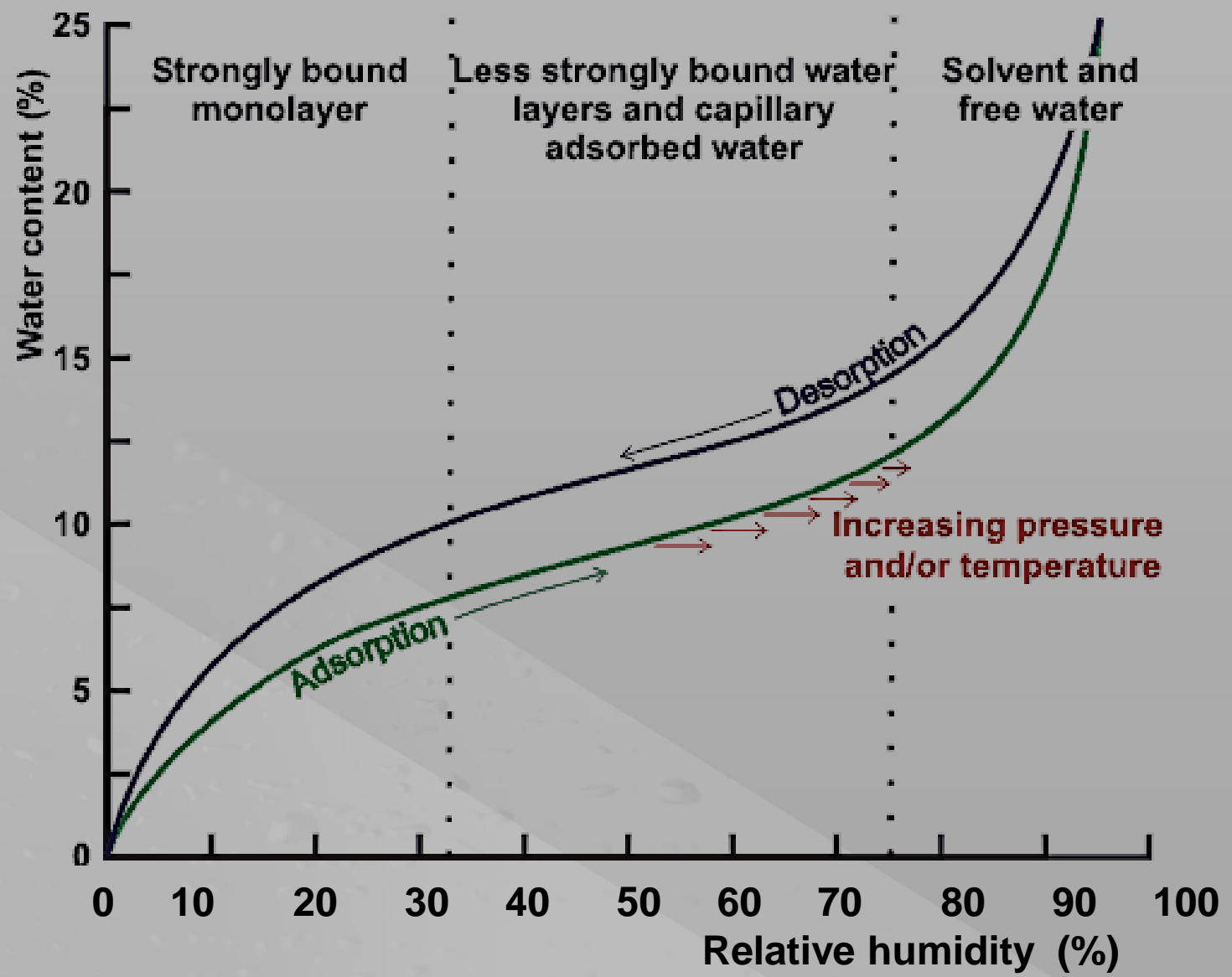



Sorption hysteresis

- shape of hysteresis curve depends on the shape of pores

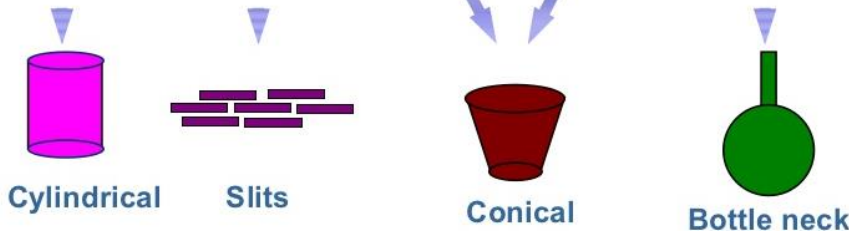
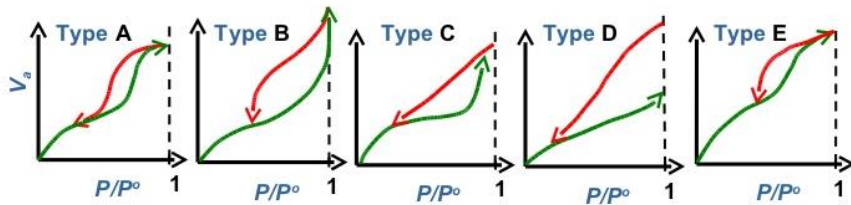

type of pores

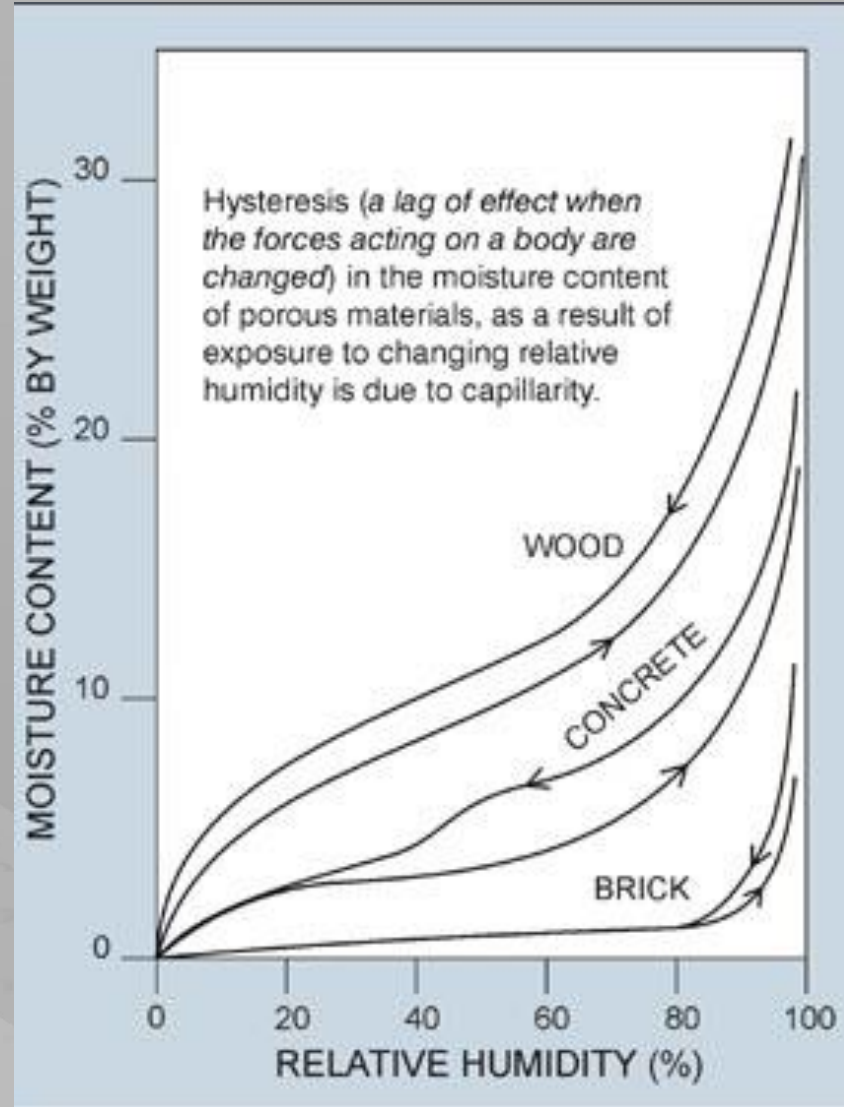



Water permeability





Water permeability

- roofing (ceramic and concrete tiles))
- depends on the amount of capillary pores and cracks (size 0,01 – 0,5 mm)

Roof tiles are always permeable

– space under roof has to be ventilated !





Water impermeability test

- measuring the time taken for a drop of water to appear on the underside of the roofing tile when a 6 cm thick water head is applied on the opposite side

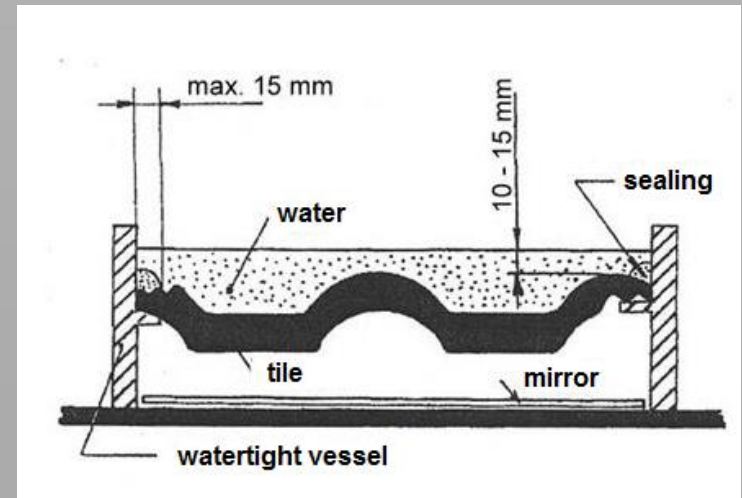

- measuring the volume of water that passes through a saturated roofing tile under a 10 cm thick water head

**Department of Materials Engineering
and Chemistry**

Faculty of Civil Engineering



Building materials



Diffusion properties



Diffusion

- gases, vapor
- spread of particles through random motion from regions of higher concentration to regions of lower concentration
- Important for:
 - vapor barriers
 - radon barriers
 - rehabilitation renders
 - paints
 - passive houses

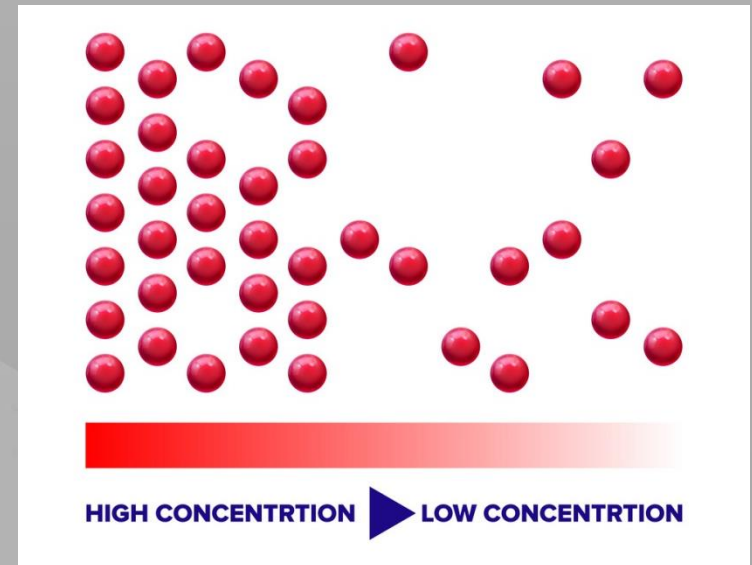



Water vapor transport

Important properties:

- the water vapor diffusion coefficient δ
- the resistance to water vapor diffusion factor μ
- the water vapor diffusion equivalent air layer thickness S_d



Water vapor permeability test

- dry cup method
- wet cup method

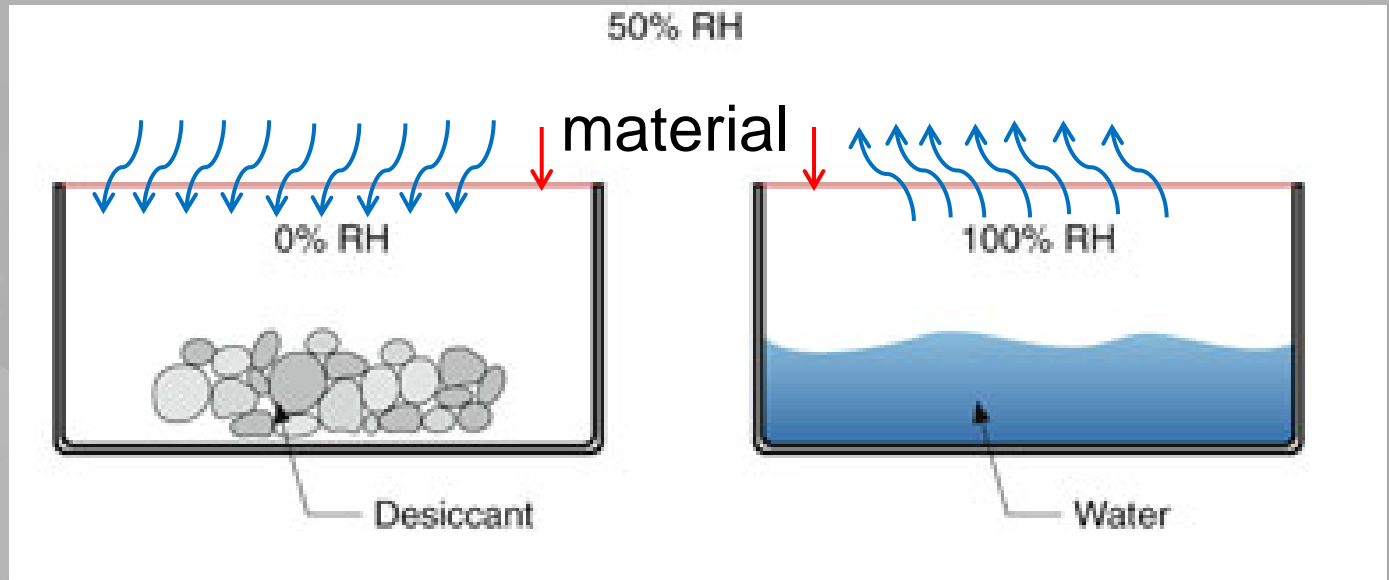

- mass increase

- mass decrease



Water vapor diffusion - - coefficient δ

- the amount of water vapor [kg] which diffuses through a layer of material which is 1 m thick and has an area of 1 m² at a partial water vapor pressure difference of 1 Pa in 1 hour
- units: [kg/m.h.Pa]

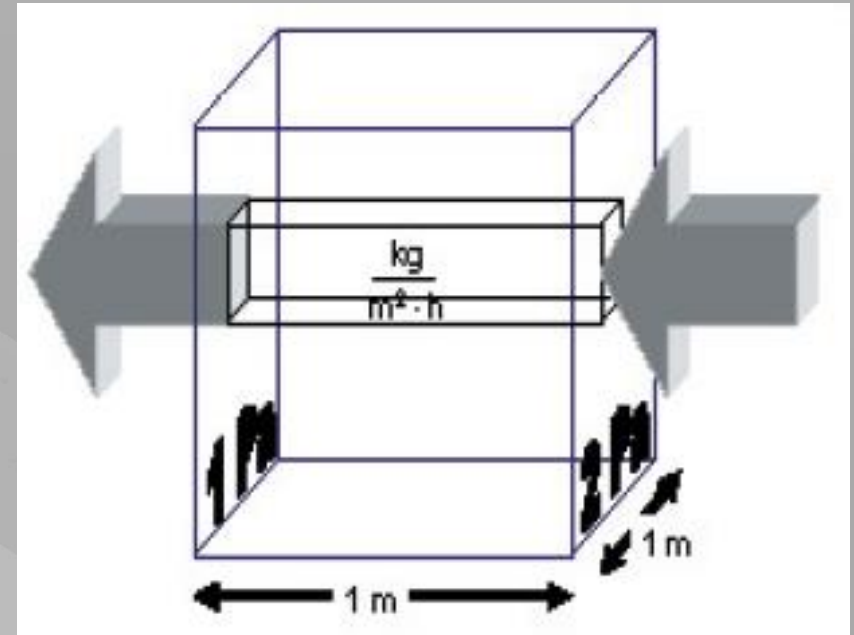



Resistance to water vapor diffusion - factor μ

- the ratio of the water vapor diffusion coefficient of the air δ_L to the value δ_{mat} of the material
- a measure for the vapor tightness of a material (how many times greater the resistance to transmission of a layer of the material is compared to a static layer of air of the same thickness)

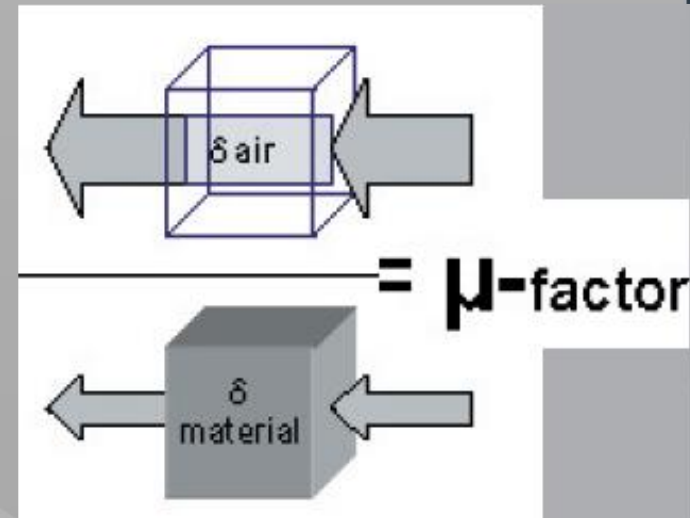



μ -value of some materials

Material	μ -value
Reinforced concrete	90
AAC (autoclaved aerated concrete)	6
Masonry of full bricks	7
Steel (plate)	600 000
Window glass	10 000
Gypsum board	12
Gypsum fibre board	10 -15
Wooden fiber plates	10
Hydrophobic plywood	60 - 100
Mineral wool	2
OSB (oriented strand board)	30
EPS (expanded polystyrene)	40
XPS (extruded polystyrene foam)	170 - 200



Equivalent air layer thickness S_d

$$S_d = \mu \cdot s \text{ [m]}$$

the thickness of a static layer of air [m], which displays the same resistance to water vapor transmission as the building material in the thickness s with the resistance to water vapor transmission value μ

Mineral wool
 $\mu \approx 3; s = 100 \text{ mm}$

$S_d = 0.3 \text{ m}$

Polyurethane
 $\mu \approx 100; s = 100 \text{ mm}$

$S_d = 10 \text{ m}$

- $S_d \leq 0.5 \text{ m} \Rightarrow$ **diffusion-open** materials
- $0.5 \text{ m} < S_d \Rightarrow$ **diffusion-blocking** materials
- $S_d \geq 1500 \text{ m} \Rightarrow$ **diffusion-proof** materials



Diffusion of coatings

Künzel's facade protection theory:

- protection and breathability of coating are influenced by water absorption capacity w and the water vapor permeability S_d

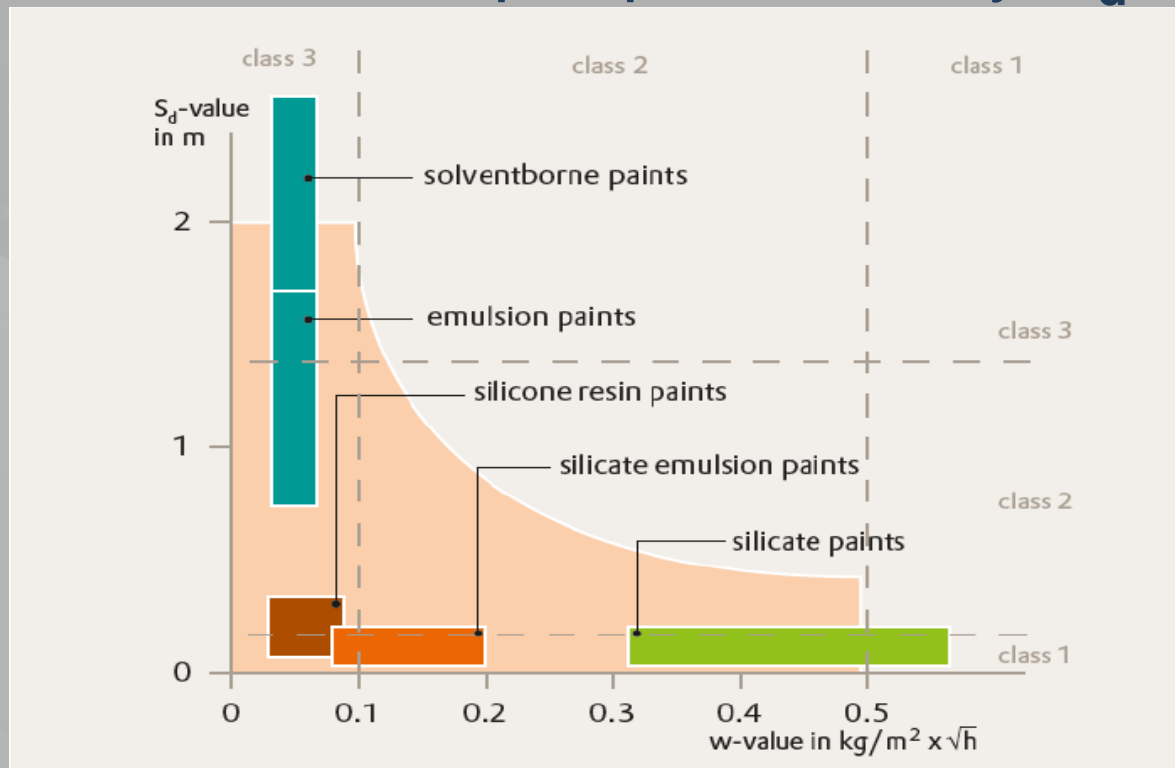



Soil permeability

- ability of soil to transmit water and air
- important in the areas with radon risk

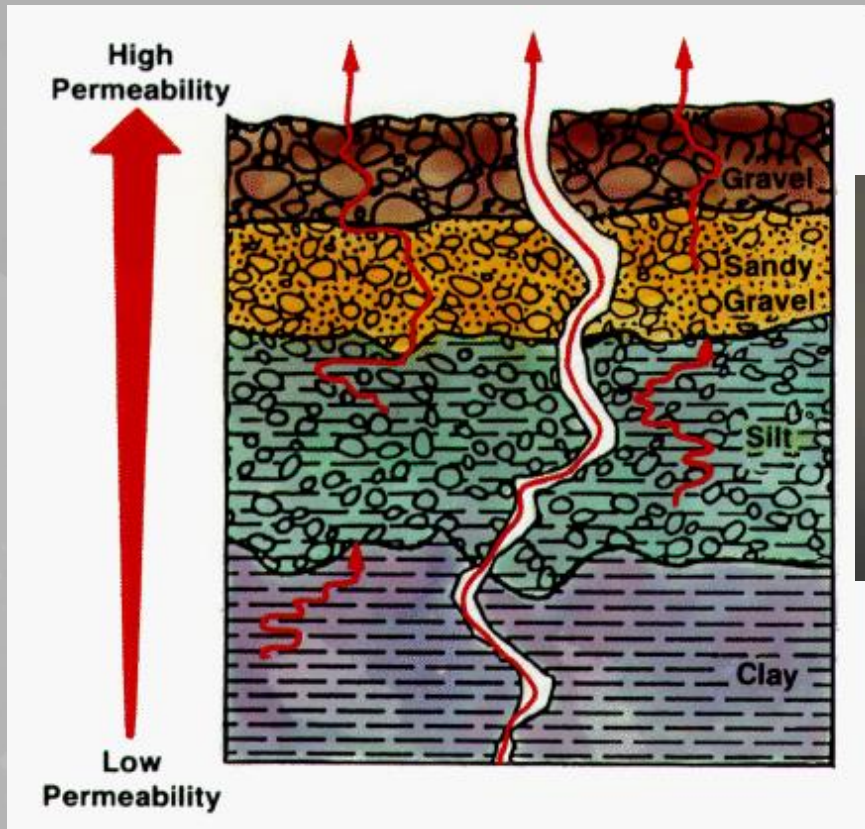

**Department of Materials Engineering
and Chemistry**

Faculty of Civil Engineering



Building materials



Thermal properties

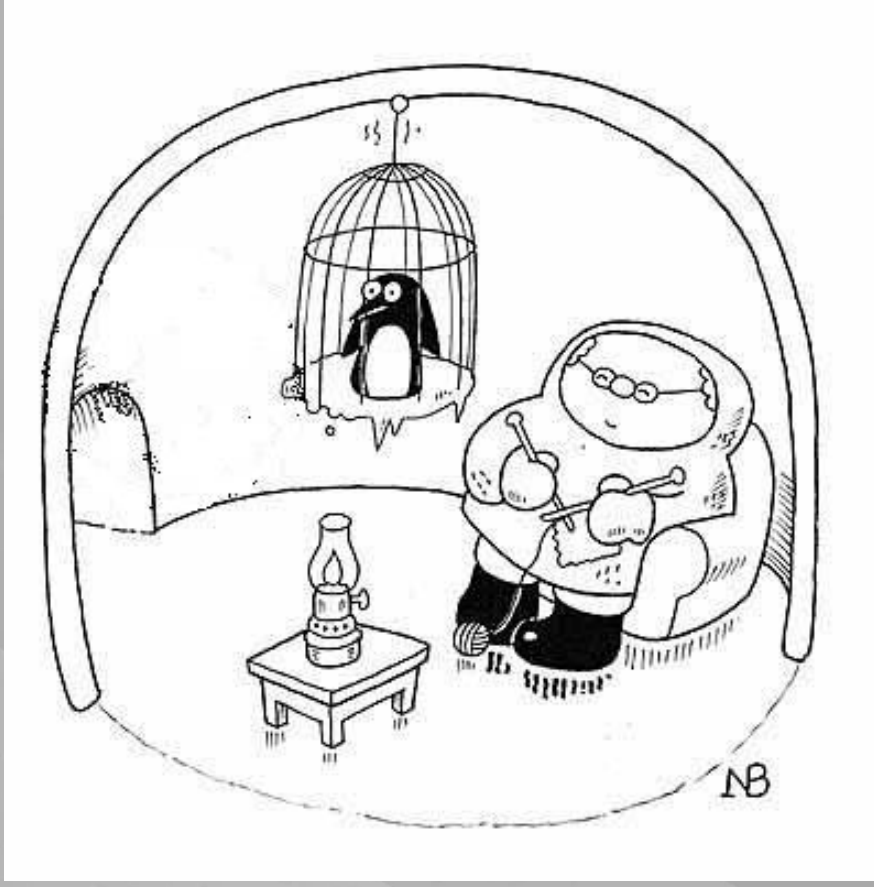



Interaction heat - material

- If the surroundings of the material has different temperature than the material, the thermal energy is transferred

Types of interaction:

1. The properties of material influence the transmission of heat
2. Thermal energy influences the properties of material



Heat transport

- **conduction – solids, gases, liquids**
 - the transfer of heat within a substance, molecule by molecule
- **convection - gases, liquids**
 - heat transfer by the mass movement of a fluid in the vertical direction
- **radiation – gases**
 - heat is transferred through wave energy

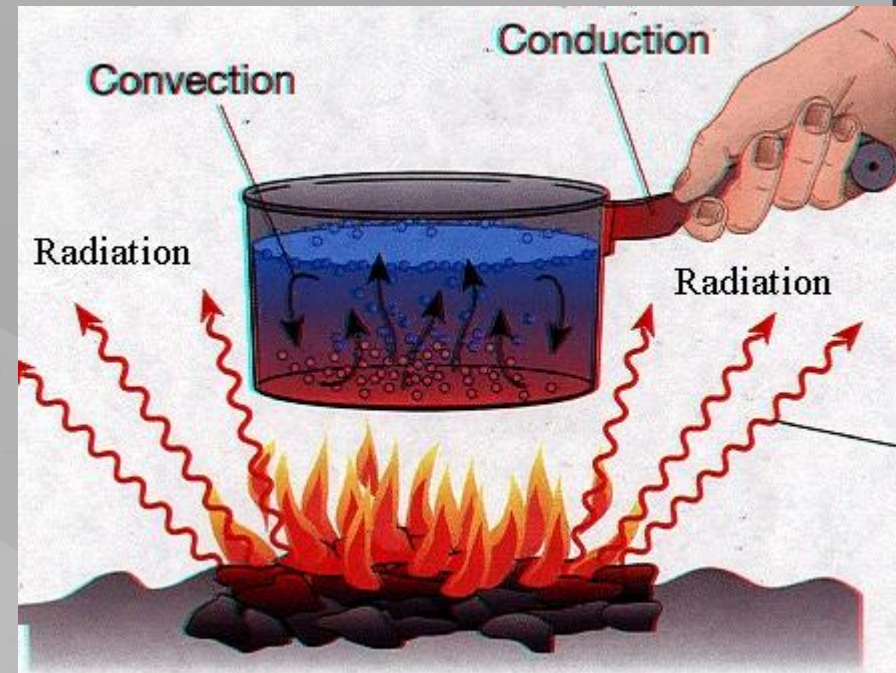



Heat transport

- In the porous materials the heat is transferred by combination of all types of heat transport

Depends on:

- **porosity**
- **structure**
- **temperature**
- **material type**

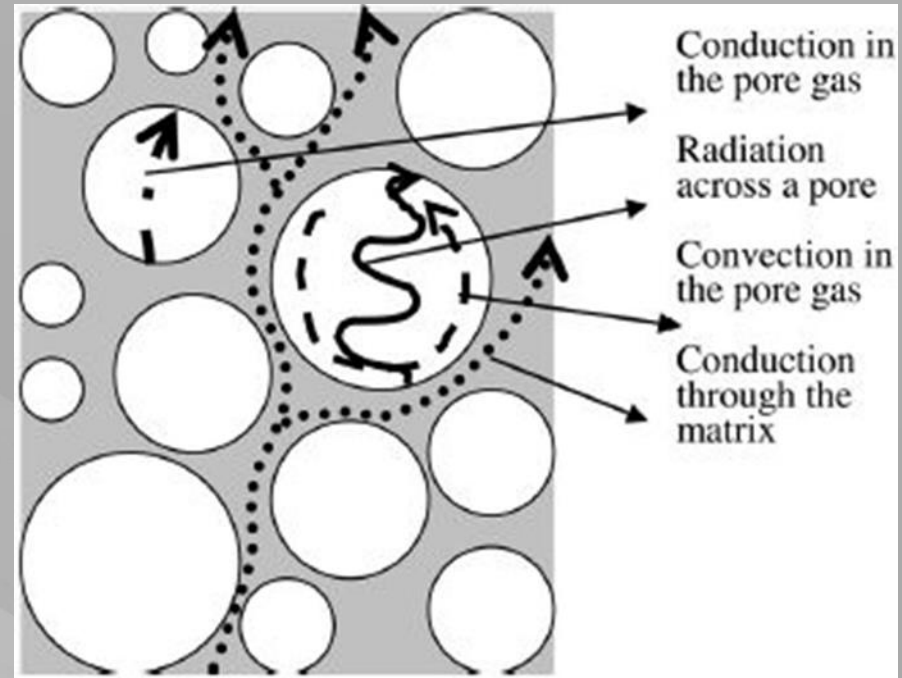



Thermal conductivity

- a material's ability to conduct heat



- (coefficient of) **thermal conductivity** λ



Thermal conductivity

- the quantity of heat transmitted, due to unit temperature gradient, in unit time under steady conditions in a direction normal to a surface
- λ (**K-value**)
- units SI: [**W/m.K**]
 - imperial units: [Btu/hr.ft.F]
(1 Btu/hr.ft.F = 1.730735 W/m.K)
- **the lower λ , the better insulator**
 - (thermal insulating materials $\lambda < 0,15$ W/m.K)
- **range λ : 10^{-2} - 10^2 W/m.K**





Thermal conductivity - comparison

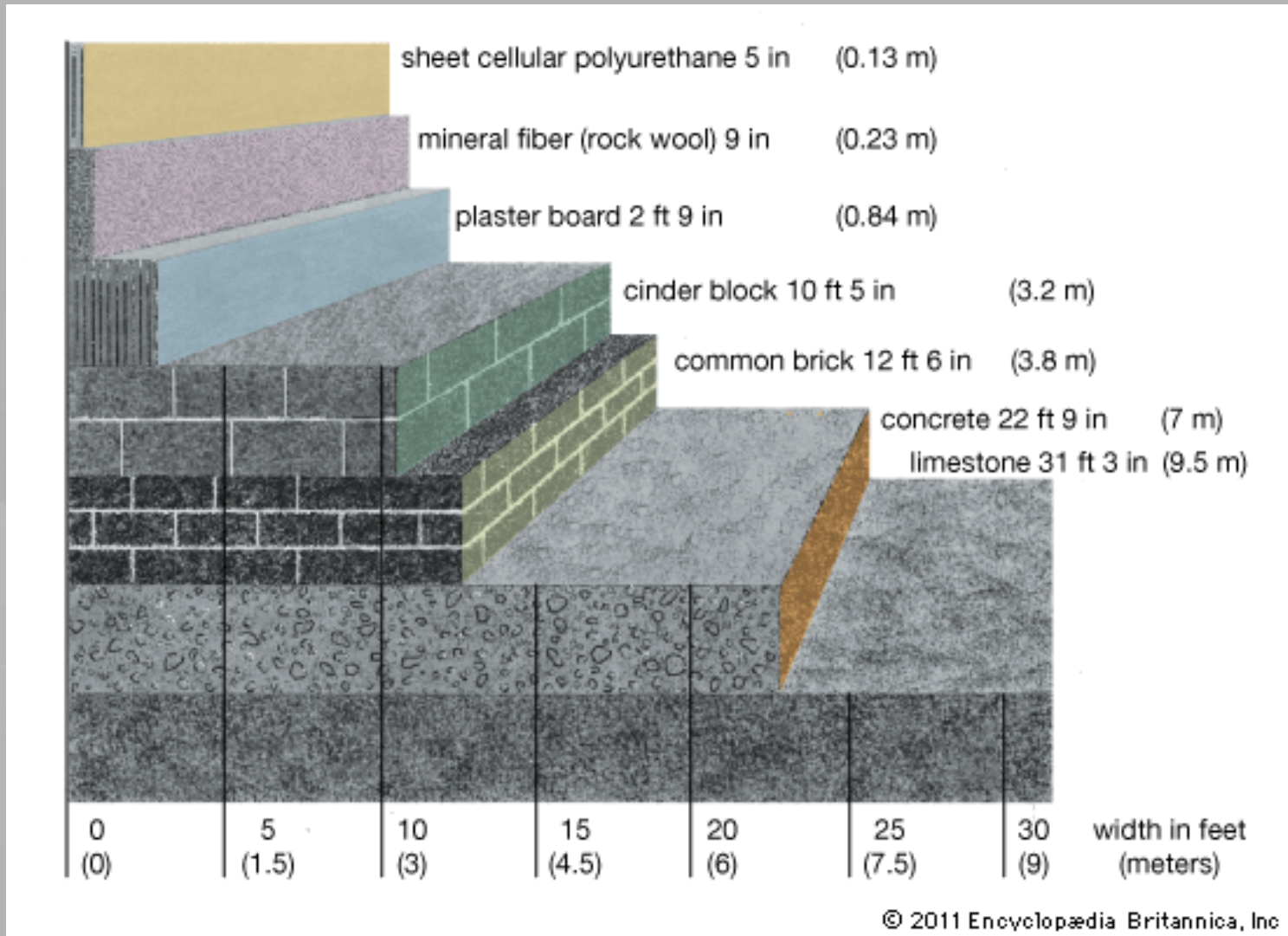



Thermal conductivity

Basic facts

- Organic materials are better insulators than inorganic m.
- Crystalline materials are better conductors than amorphous m.
- Materials with lower bulk density are usually better insulators.
- Metals are very good conductors.
- Anisotropic materials have different conductivity in different directions.





Thermal conductivity

Depends on:

- chemical composition
- structure
- porosity (bulk density)
- moisture
- temperature

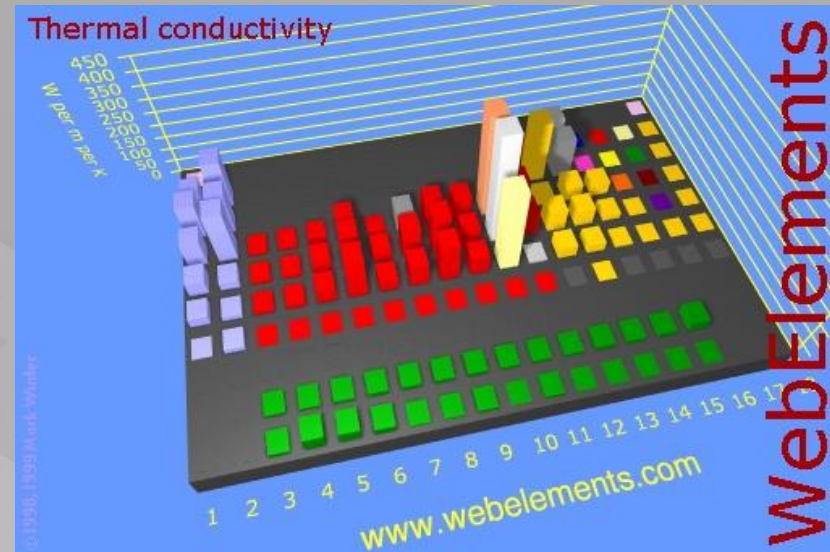



Influence of porosity on thermal conductivity

- $\lambda_{\text{AIR}} = 0,025 \text{ W.m}^{-1}.\text{K}^{-1}$
- the higher the amount of air in the material (porosity), the lower bulk density and thermal conductivity is
- size of pores is limited (best 0,1 – 1 mm) (because of capillarity)





Porosity x thermal conductivity

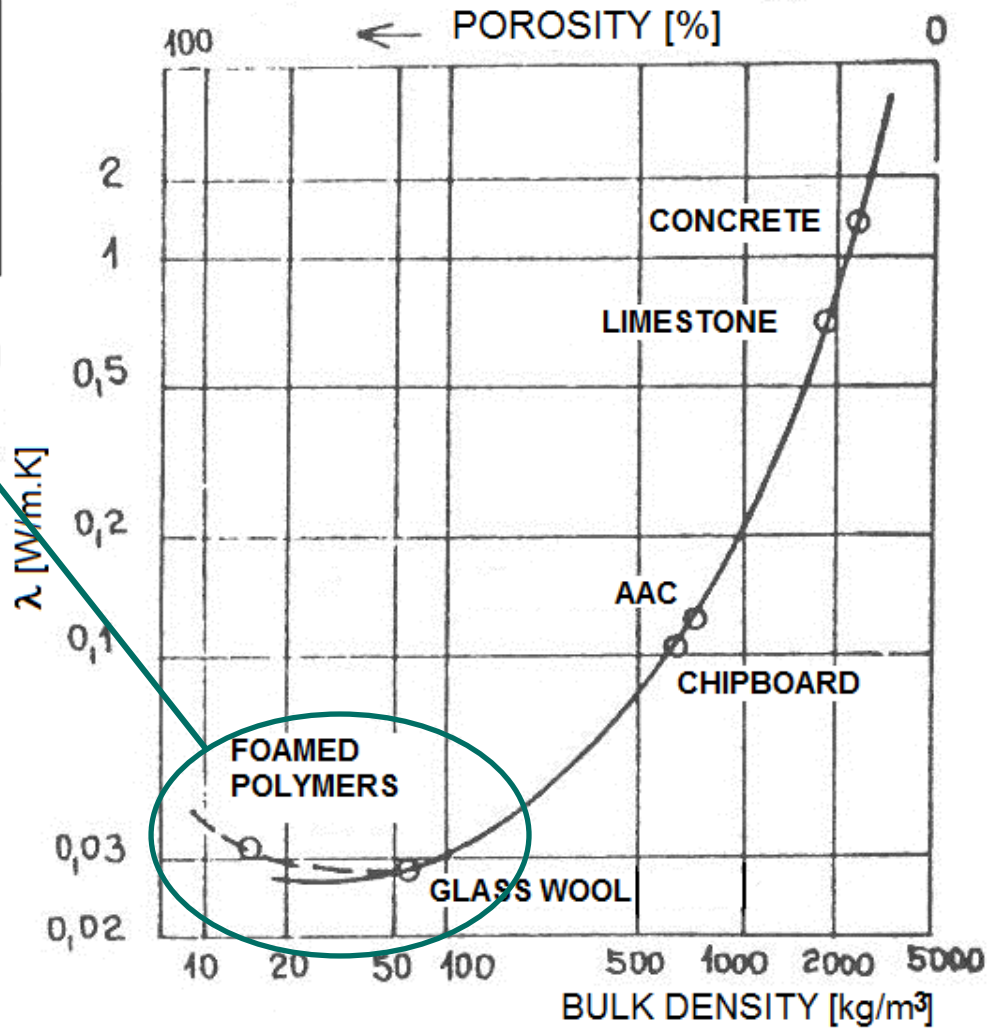
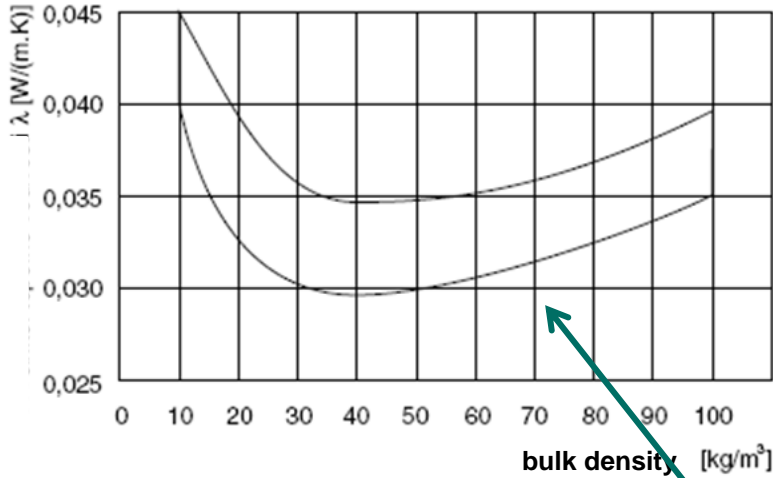

EPS



Influence of moisture on thermal conductivity

λ_{water} app. 25 x higher than λ_{air}



- moisture significantly reduces the thermal insulating ability of materials
- very small pores are liable to wetting (capillarity) – the best size of pores in insulating materials: 0,1 – 1 mm



Moisture x thermal conductivity

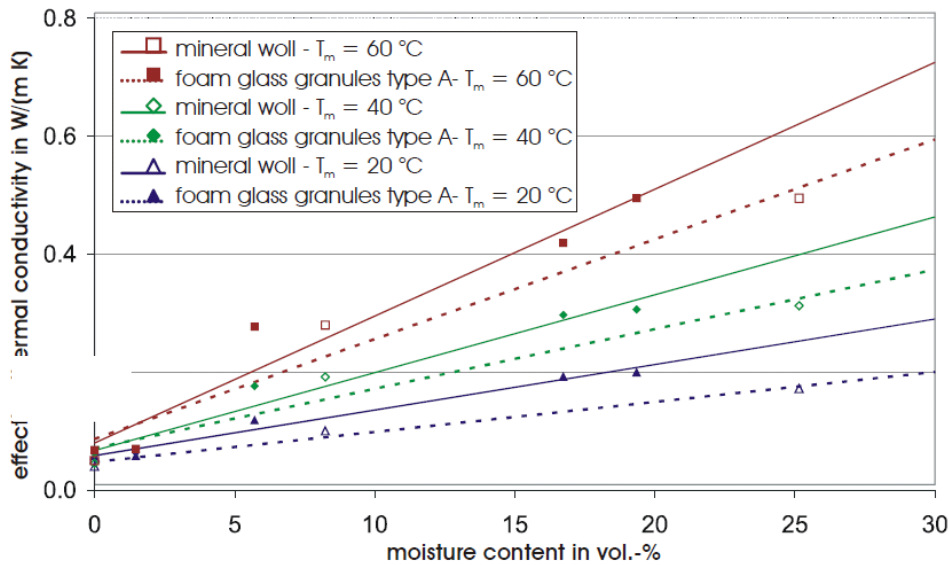
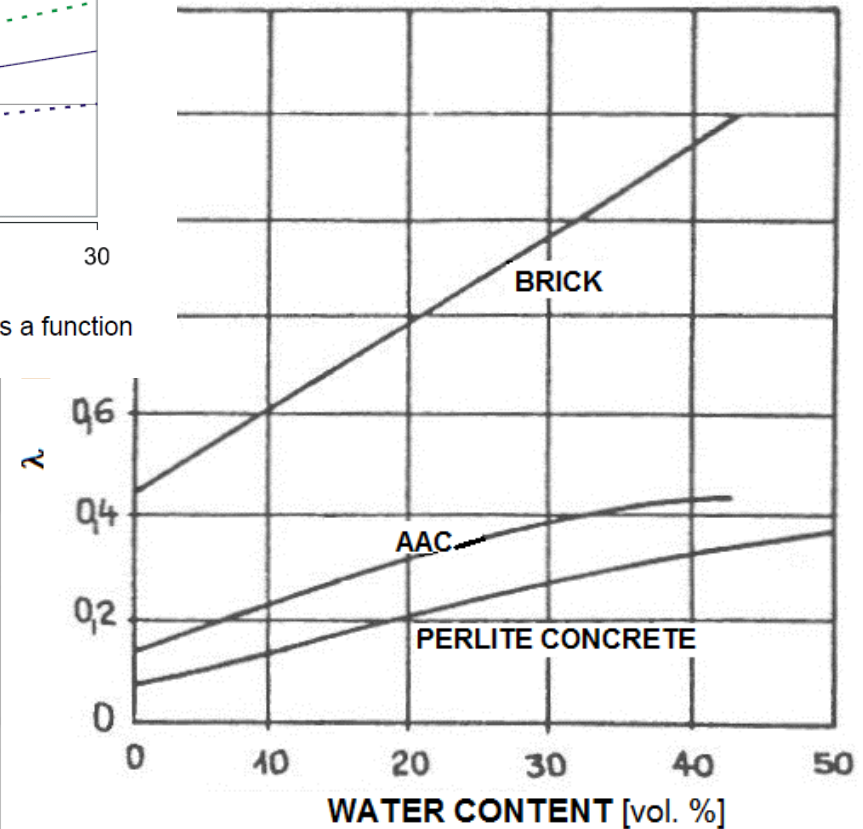

Figure 5: Thermal conductivity of mineral wool and foam glass granules as a function of the volume related moisture content and the temperature.





Influence of temperature on thermal conductivity

- λ increases with rising temperature

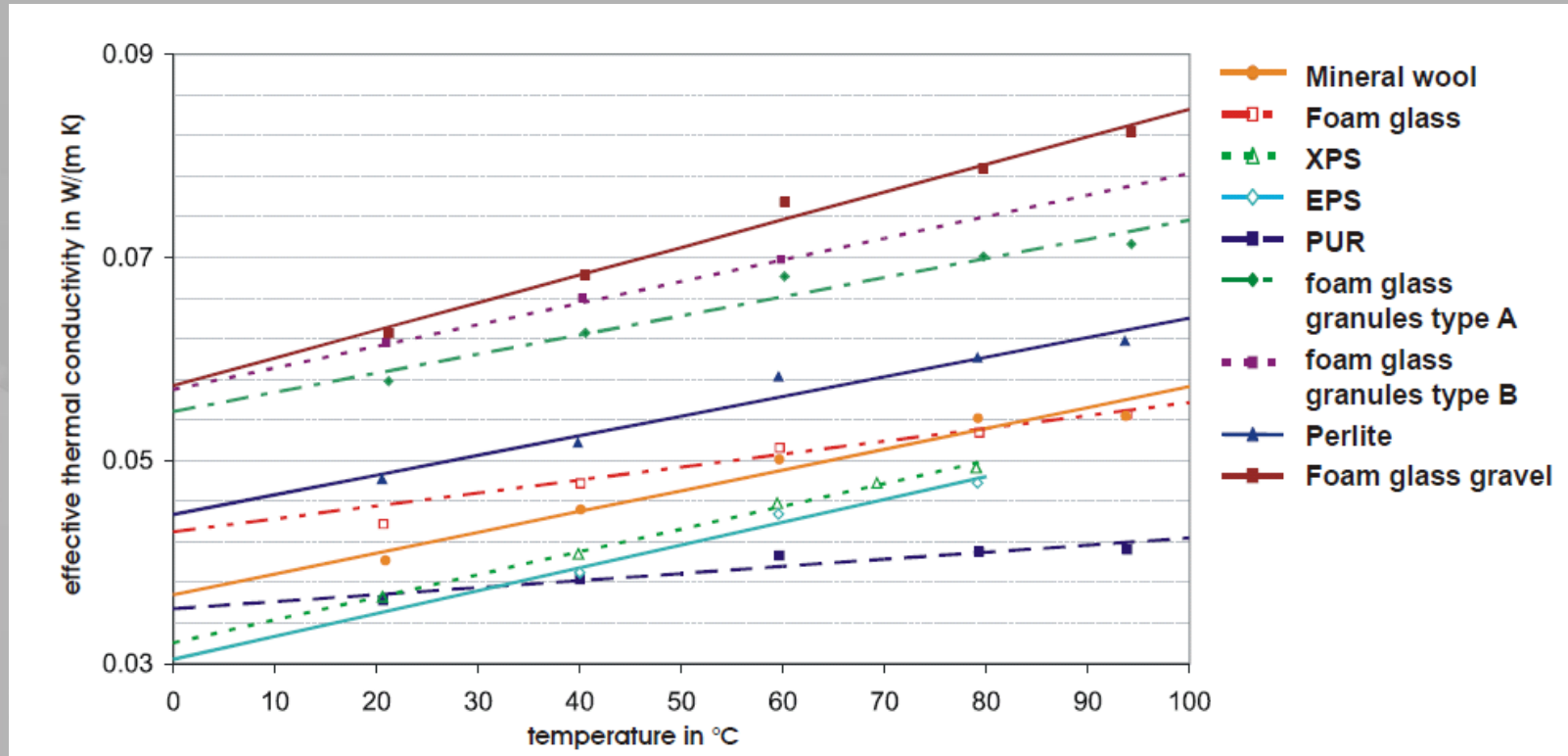

$$\lambda_t = \lambda_0 + 0,0025t \quad (\text{for } t = 0 - 100^\circ\text{C})$$



Thermal insulating materials - overview

- **fibrous**
 - mineral and glass fibers
 - wood wool (excelsior)
 - cellulose fibers
 - recycled paper fibers
 - straw (bales, loose)



- **porous particles**
 - expanded clay aggregate
 - expanded perlite
 - ash
 - cinders





Thermal insulating materials

- **shaped**

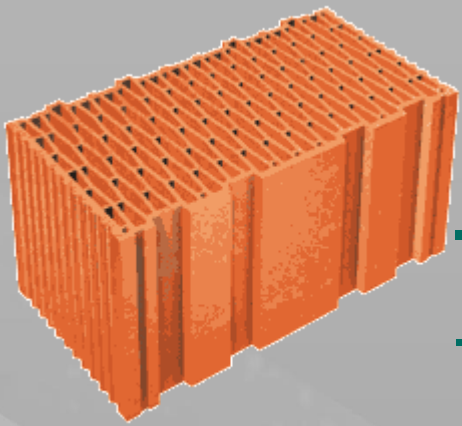

- **lightweight concretes** (with lightweight aggregates, pervious c., aerated concretes)
- **insulating brick blocks**
- **diatomite**

- **foamed**



- **foamed polymers** (PU, PS, phenolic foam)
- **cellular glass**





Thermal insulating materials

- other
 - cork (expanded)
 - wood
 - wood-based materials (fiber board, particle board)
 - lamb wool





Best insulation?

- vacuum
- „VIP“ = Vacuum Insulated Panel
- a nearly gas-tight enclosure surrounding a rigid core, from which the air has been evacuated
- $\lambda = 0,004 - 0,008 \text{ W/m}\cdot\text{K}$

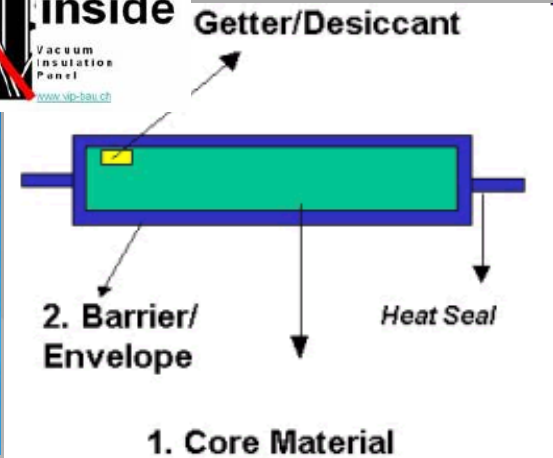
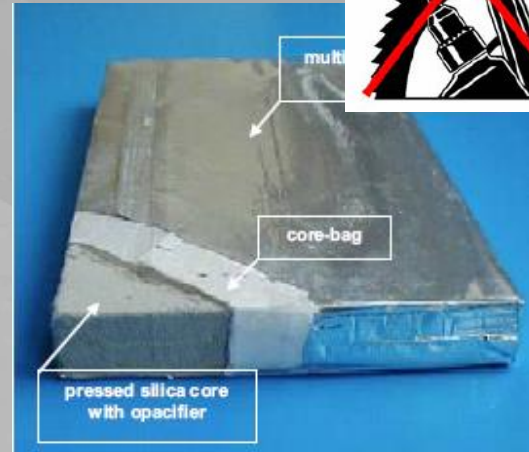



Common available insulation materials

INSULATION MATERIAL	THERMAL CONDUCTIVITY W/MK - LESS INDICATES BETTER PERFORMANCE	THERMAL RESISTANCE M2K/W - MORE INDICATE BETTER PERFORMANCE	U - VALUE W/M2K
Mineral Wool			
Glass fibre	0.032 - 0.044	3.10 - 2.25	0.32 - 0.44
Rock fibre	0.035 - 0.044	2.85 - 2.25	0.35 - 0.44
Sheep's wool	0.042	2.38	0.42
Expanded polystyrene (EPS)	0.036	2.77	0.36
Multi-foils	0.040	The nature of this insulant does not lend itself directly to direct comparison on thermal resistance or stand alone U-value	
Hemp	0.039	2.56	0.39
Extruded polystyrene (XPS)	0.029 - 0.036	3.44 - 2.77	0.29 - 0.36
Polyurethane foam board (PUR)	0.22 - 0.29	0.45 - 3.44	2.22 - 0.29
Polyisocyanurate foam board (PIR)	0.021 - 0.022	4.76 - 4.54	0.21 - 0.22
Phenolic foam board	0.021	4.76	0.21
Evacuated panels - 20mm thk	0.004	5.00	0.20
Aerogel board - 10mm thk	0.013	0.77	1.29

Thermal resistance figures are based 100mm thickness of insulation material

Thermal conductivity figures are typical for each material and may vary slightly between manufacturers

U - values shown indicate heat loss in watts / sq.m degree for insulation product alone

**Department of Materials Engineering
and Chemistry**

Faculty of Civil Engineering



Building materials



Thermal conductivity measuring

- **steady-state methods** - the temperature of the measured material does not change with time
- **transient (non steady-state) methods** - a measurement during the process of heating up

Steady state - a situation in which all variables are constant in spite of ongoing processes that strive to change them. For an entire system to be at steady state, i.e. for all state variables of a system to be constant, there must be a flow through the system



Thermal conductivity measuring

Steady-state methods:

- Guarded hot plate
- Divided bar
- Hot box



Transient methods:

- Hot wire
- Plane source
- Needle probe
- Laser flash method

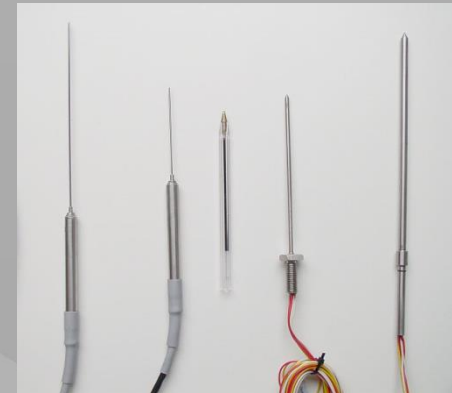



Building materials

Thermal conductivity measuring

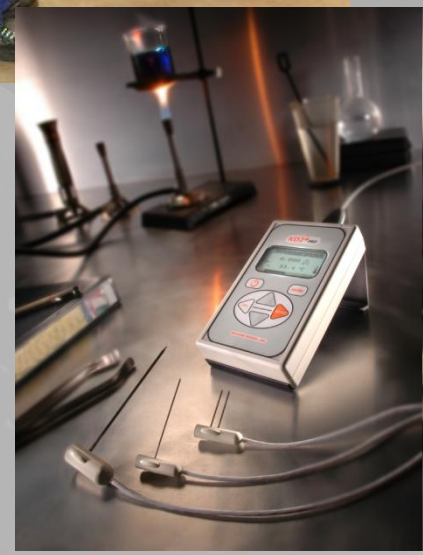

Department of Materials Engineering and Chemistry
Faculty of Civil Engineering





Thermal conductivity determination

- Steady state method:

$$\lambda = \frac{q \times d}{T_1 - T_2}$$

$$q = \frac{Q}{A}$$

- q of heat passing through a unit area of the sample in unit time [W/m²]
 d average thickness of sample [m]
 T_1 temperature of warm side of the sample [K]
 T_2 ... temperature of cold side of the sample [K]
 Q quantity of heat passing through a base area of the sample [W]
 A base area of the sample [m²]



Guarded hot plate

- placing a solid sample of fixed dimension between two temperature-controlled plates
- one plate is heated while the other plate is cooled, and their temperatures are monitored until they are constant

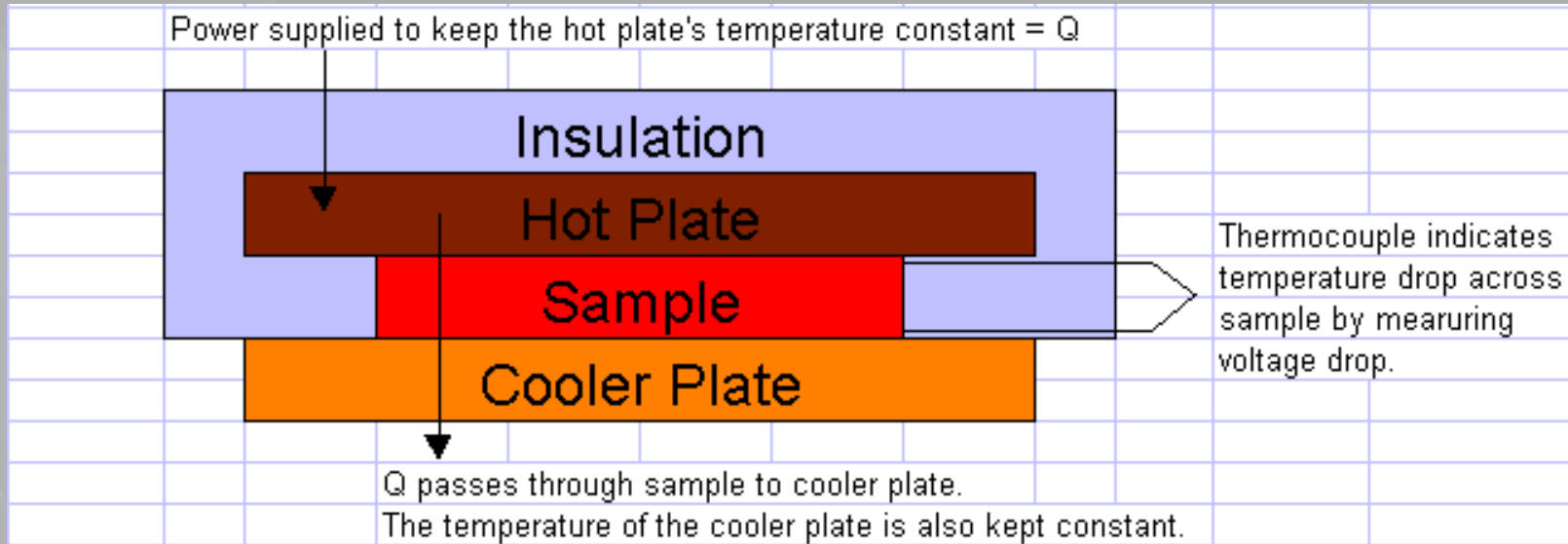



Material

λ [W.m⁻¹.K⁻¹]

- Copper ~370
- Aluminium ~200
- Carbon steel ~50
- Concrete ~1,4
- Glass ~0,75
- Brick ~0,7
- **Water (20° C, quiet)..... ~0,60**

- Wood ~0,15
- Mineral fibers ~0,05
- Polystyrene foamed ~0,035
- **Air (dry, quiet) 0,025**
- Argon (quiet) ~0,015

thermal insulations



Thermal resistance R-value

$$R = d / \lambda \text{ [(m}^2 \cdot \text{K) / W]}$$

- directly proportional to the thickness of the material
- for construction, not material
- can be used for masonry blocks

$$R = 0,65 \text{ (m}^2 \cdot \text{K)/W}$$

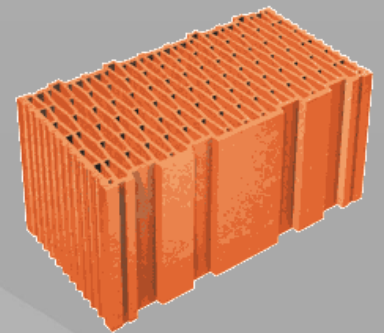



Thermal resistance

- multi-layered construction : the R-values of the individual layers are summed

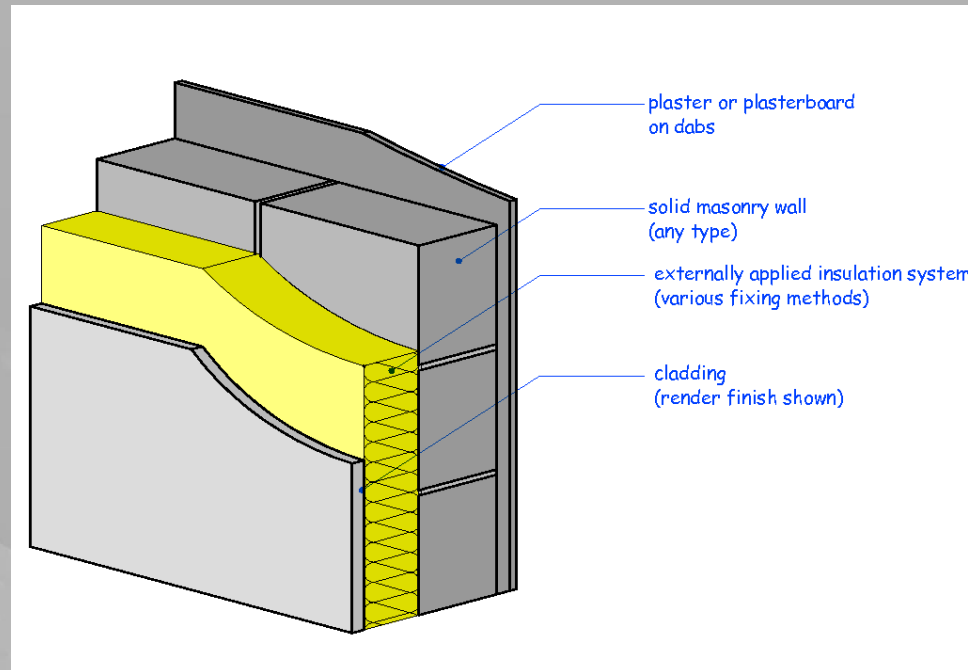

$$R_{\text{total}} = R_{\text{outside air film}} + R_{\text{render}} + R_{\text{insulation}} + R_{\text{brick}} + R_{\text{plaster}} + R_{\text{inside air film}}$$



Thermal transmittance U-value

- the measure of the rate of heat loss through a material
- incorporates the thermal conductance of a structure along with heat transfer due to convection and radiation

$$U\text{-value} = 1/R$$
$$[W / m^2 \cdot K]$$

U Values of different types of glazing
(2.0 W/m²K is the Document L Threshold for Windows)

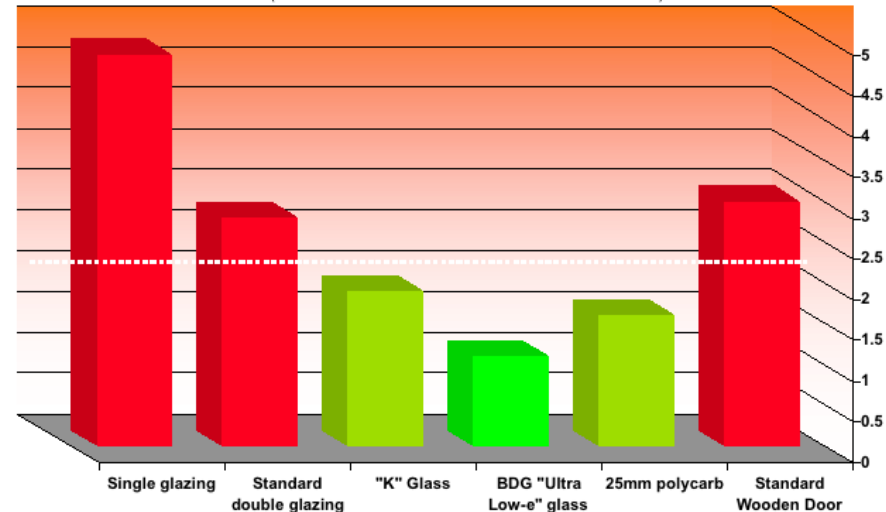



U-value in Europe

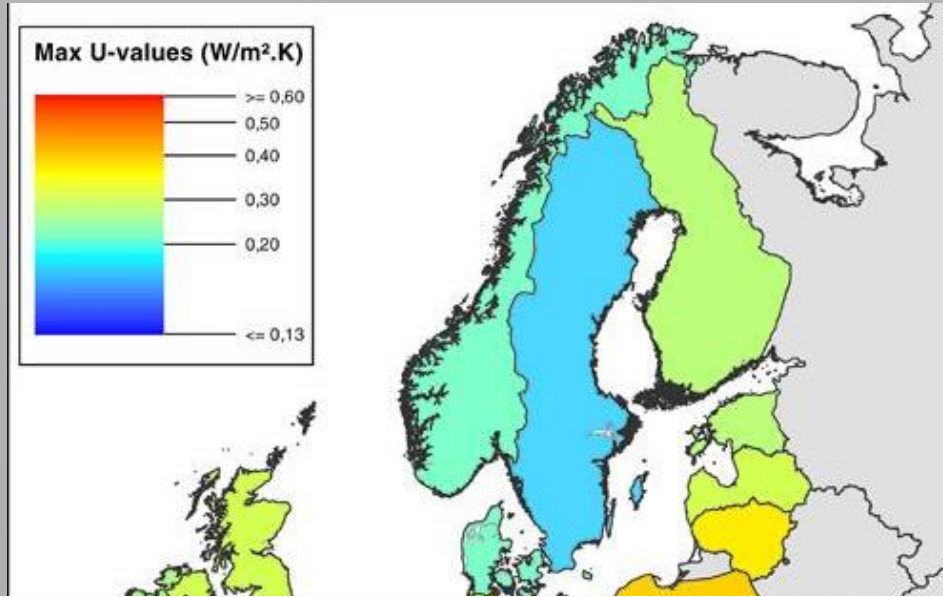

Rank	Country	Walls	Country	Roof	Country	Floor	Country	Windows
1	Sweden	0.3	Sweden	0.2	Sweden	0.2	Finland	1.9
2	Finland	0.4	Denmark	0.3	Denmark	0.4	Austria	2.3
3	Denmark	0.5	Finland	0.3	Finland	0.4	Denmark	2.4
4	Czech Republic	0.8	Czech Republic	0.6	Germany	0.8	Sweden	2.5
5	Austria	0.9	Austria	0.6	Czech Republic	0.9	Germany	2.7
6	Germany	0.9	Ireland	0.7	Belgium	0.9	Czech Republic	2.7
7	UK	1.0	Germany	0.7	France	1.0	France	3.1
8	Netherlands	1.1	UK	1.1	Ireland	1.0	Netherlands	3.2
9	France	1.2	Netherlands	1.2	Austria	1.0	Belgium	3.8
10	Ireland	1.2	France	1.3	UK	1.2	Ireland	3.8
11	Belgium	1.5	Belgium	1.6	Netherlands	1.3	UK	3.9



Heat losses

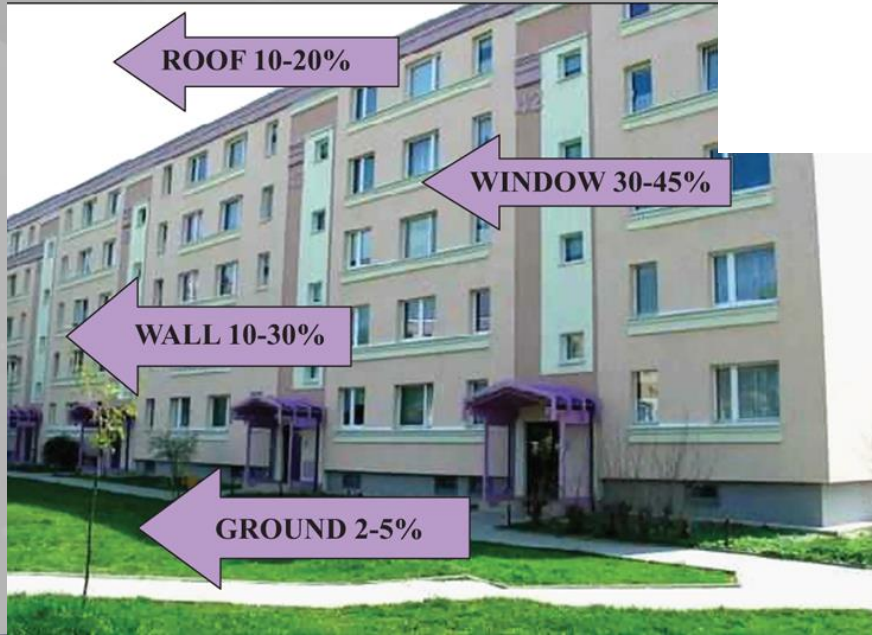
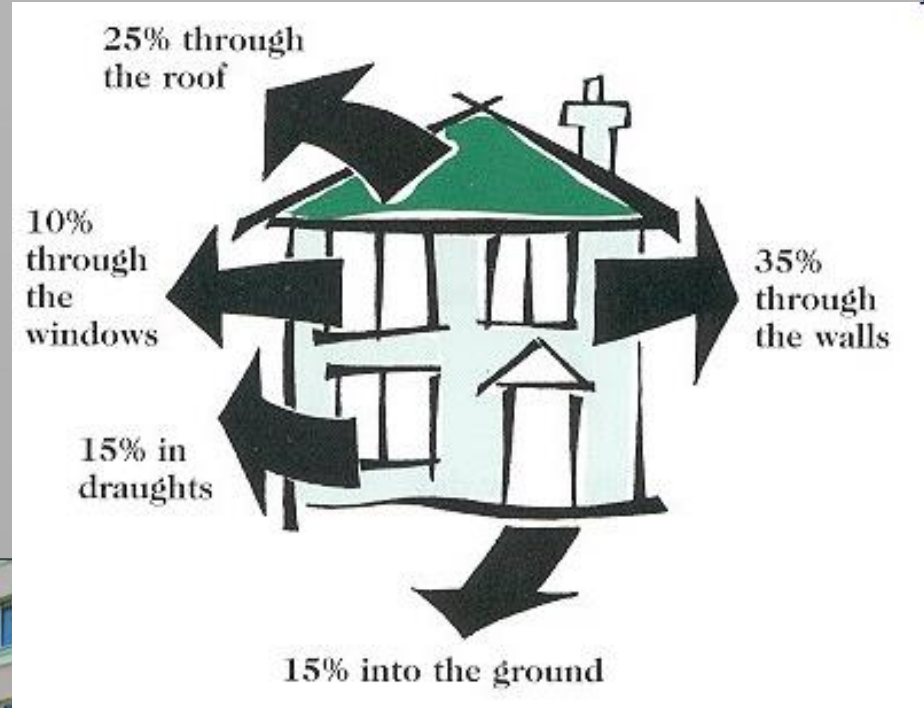



Specific heat capacity c

= specific heat

- the amount of heat required to change 1 kg of substance's temperature by a 1 K
- units: $[\text{J} \cdot \text{kg}^{-1} \cdot \text{K}^{-1}]$

Depends on:

- temperature
- moisture: $c = c_0 + 0,42 w_m$

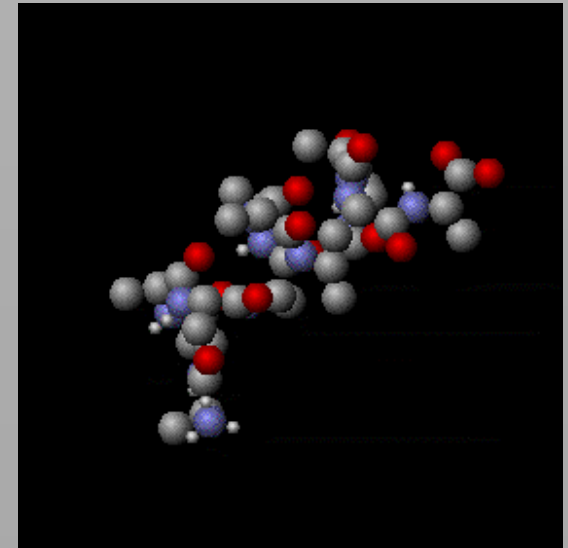



Specific heat of some materials

Material	C [kJ.kg ⁻¹ .K ⁻¹]
asphalt	0,92
concrete	0,88
brick	0,84
glass	0,84
copper	0,39
granite	0,79
gypsum	1,09
water	4,18
wood to fibers	0,42





Heat accumulation

Thermal mass of building

- absorbs thermal energy when the surroundings has higher temperature than the material and give thermal energy back when the surroundings are cooler

SUMMER SUN CONTROL AND THERMAL MASS

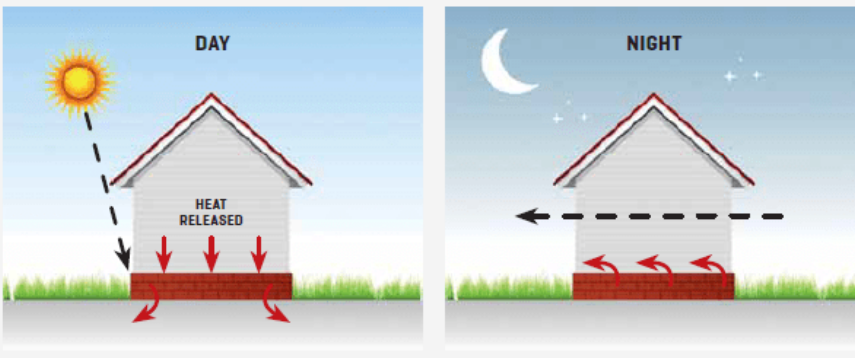

WINTER SUN CONTROL AND THERMAL MASS

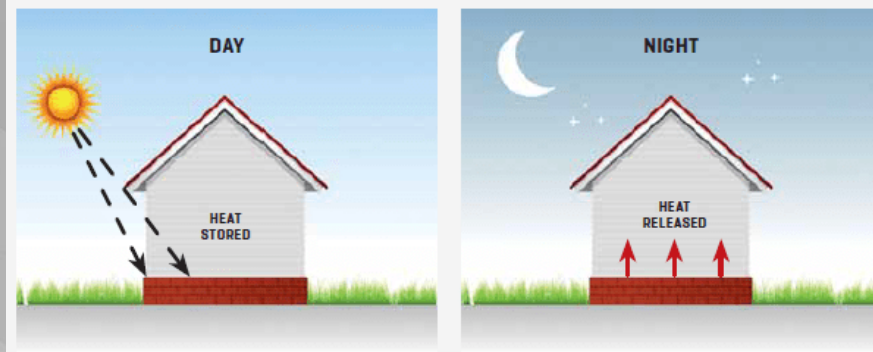



Interior thermal control

Phase - change materials (PCM)

- materials with very high latent heat storage capacities
- best melting point for building purposes about 25 °C
- heat is absorbed or released when the material changes from solid to liquid and vice versa



- **Materials:**
 - paraffin
 - fatty acids
 - salt hydrates





Thermal effusivity

- determines the interfacial temperature when two semi-infinite objects at different temperatures touch

$$\mathbf{b} = \sqrt{\lambda \cdot \mathbf{c} \cdot \rho \cdot v}$$



- units: [$\text{W} \cdot \text{s}^{0,5} \cdot \text{m}^{-2} \cdot \text{K}^{-1}$]
- the higher \mathbf{b} is, the colder sensation gives the material



Thermal comfort

- the condition of mind which expresses satisfaction with the thermal environment
- affected by
 - air temperature
 - temp. of surrounding surfaces
 - air flow velocity

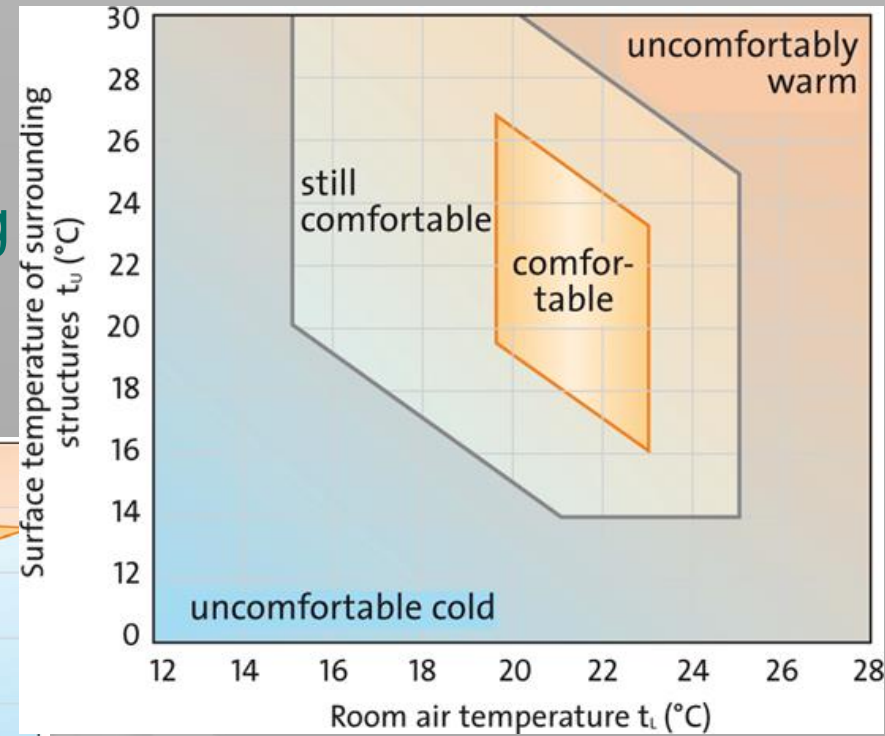
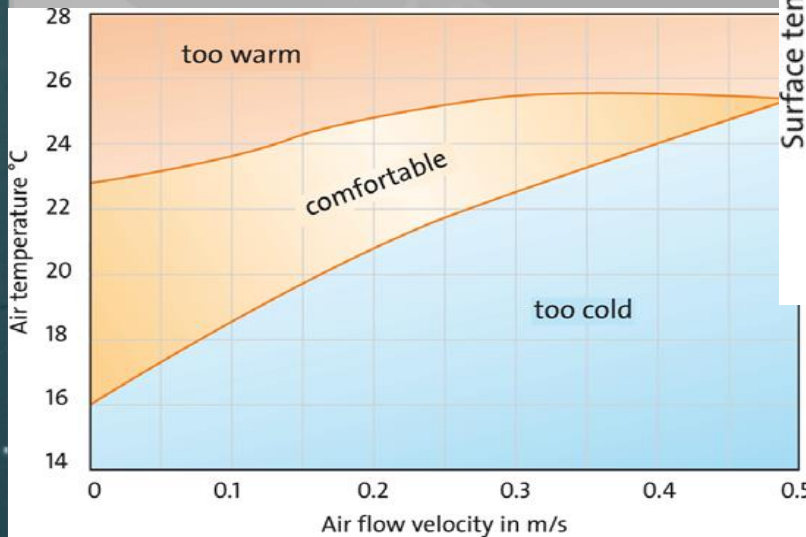



Reflectivity

- the ability of a surface to reflect radiation
- light reflectivity - the percentage light reflected from a surface at a given wavelength.

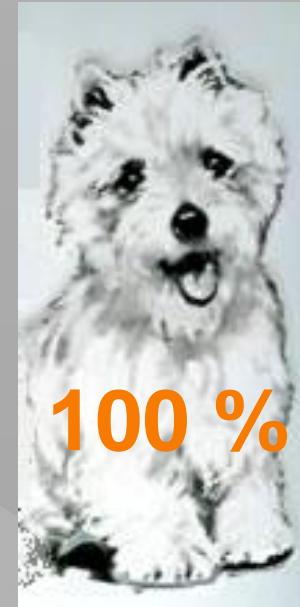
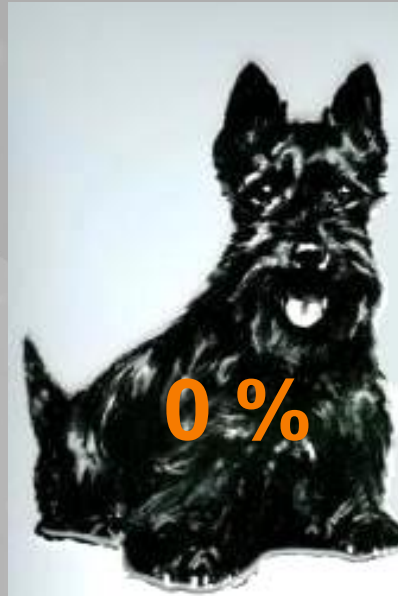



Heat reflection and absorption

- reflection ρ
- absorption α

$$\alpha + \rho = 1$$

Heat reflectance:

$$R = \frac{\alpha}{\text{incident heat}}$$

- black body $R = 1$
- white $R = 0,5$

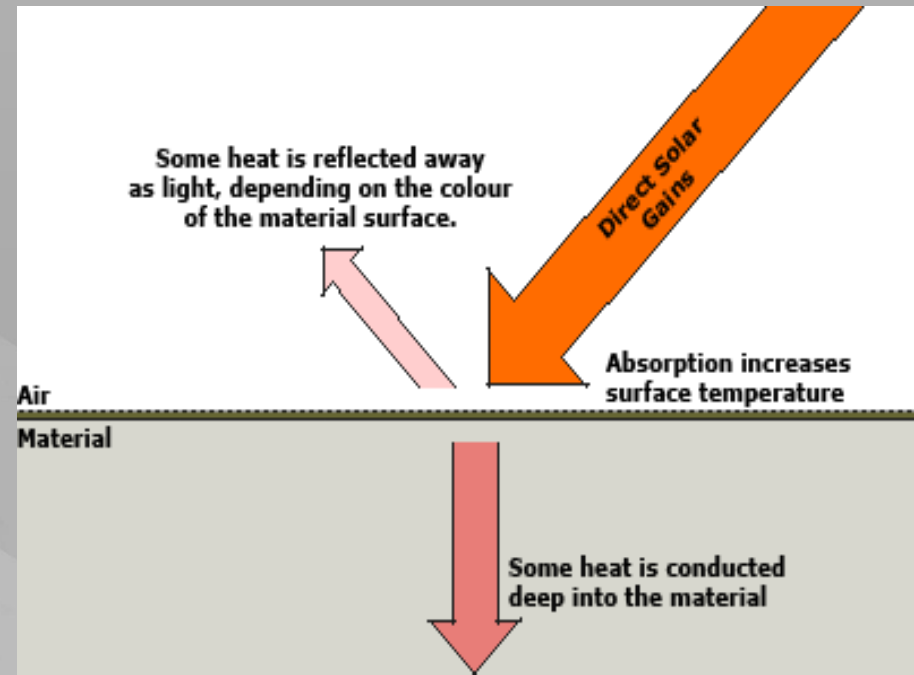



Solar absorptivity

Solar Absorptivity Chart for Selected Colours

Code	Colour	Absorptivity
6068	Black	0.94
6062	Dark Brown	0.91
6154	Metro Brown	0.89
6073	Dark Green	0.89
6072	Charcoal	0.89
6084	Navy Blue	0.87
6079	Heron Blue	0.85
6078	Green	0.84
6067	Slate Blue	0.8
6082	Regent Grey	0.75
6071	Stone Grey	0.6





Heat reflective paints

